



Quality Tools For The Electronics Industry



**SYNERGY**  
ELECTRONICS LTD

sales@synergielectronics.co.nz  
www.synergielectronics.co.nz  
Ph 0800 347 045

# HAKKO Gio



## HAKKO brand is much loved in more than 50 countries worldwide.

HAKKO has grown into a global brand. Our soldering irons and related equipment are hard at work in more than 50 countries. We have local branches and sales representatives around the world, and continue to expand our global network.



<http://www.hakko.com>

 **HAKKO** is registered in countries and regions including the following. Japan, USA, South Korea, Singapore, China, the member of CTM.

# Global Network



As of Feb. 2018

## 《《《 WORLDWIDE NETWORK 》》》



For more details on HAKKO affiliates and distributors, visit the official HAKKO website at [www.hakko.com](http://www.hakko.com)



# HAKKO products pioneer

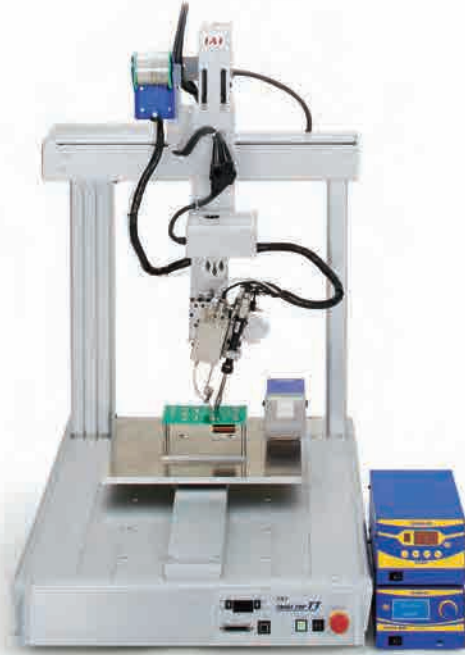

A Smart Way to build an Auto-Soldering System

**FU-500** ESD SAFE

**FU-600** ESD SAFE

**FU-601** ESD SAFE

P.10

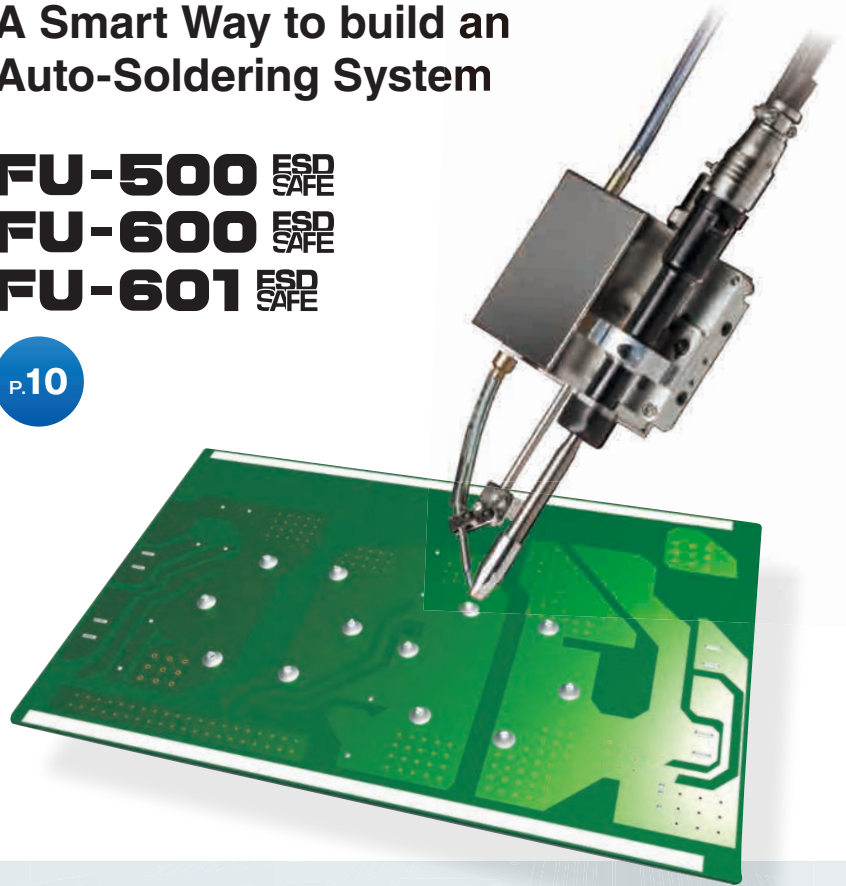

## AUTO-SOLDERING

A next generation IH soldering iron

**FX-1002** ESD SAFE

P.26

## MICRO SOLDERING

Ideal for Micro Soldering applications under a microscope

**FM-2032** ESD SAFE

Connectable to the stations below

FX-951 5脚 FM-203 5脚 FM-206 5脚

P.22

P.30

P.30





# the next generation

Super Power of 300 W Heater

**FX-801** ESD SAFE

P.14



# POWER SOLDERING™



**FR-400** ESD SAFE

P.66

# WIRE HARNESS ASSEMBLY

Thermal wire stripper  
Excellent stripping  
performance



**FT-801** ESD SAFE

P.54



Powerful & Fine  
The new heating gun



**FV-310** P.98



# Quality Tools for the



HAKKO is certified under ISO 9001 (JIS Q 9001), the international standard for quality management systems. We are also certified under ISO 14001 (JIS Q 14001) and are actively involved in preserving the global environment.

See the official HAKKO website for all necessary information regarding HAKKO products and services.

## • HAKKO WEBSITE



## • SELECT TIP SHAPE

Search for the appropriate tip for your work by following the guidelines.



[http://www.hakko.com/english/tip\\_selection/](http://www.hakko.com/english/tip_selection/)

## • DOCUMENT PORTAL

Download instruction manuals, SDSs, and technical documents from the HAKKO Document Portal.



<https://doc.hakko.com/?l=en>

# Electronics Industry

New  
Products

**HAKKO FX-1002** SOLDERING IRON **ESD SAFE**

Micro Soldering Iron

Page  
27



**HAKKO FR-301** DESOLDERING TOOL

Portable Desoldering Tool

Page  
64



**HAKKO FR-701** REPAIR SYSTEM **ESD SAFE**

Repair System

Page  
80



**HAKKO FR-702** REWORK SYSTEM **ESD SAFE**

Rework System

Page  
81



**HAKKO FR-811** SMD REWORK STATION **ESD SAFE**

Hot-Air SMD Rework Station

Page  
72



**HAKKO FA-431** FUME EXTRACTION **ESD SAFE**

Air-Purifying Smoke Absorber

Page  
85



**HAKKO FV-310** HEATING GUN

Heating Gun

Page  
98





# Index

## Auto-Soldering System

### Auto-Soldering System

**FU-500**  
Solder Feed Unit

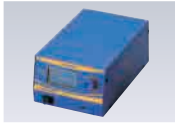

P.10

**FU-600 & FU-601**  
Soldering Iron Unit

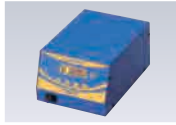

P.10

**FU-6001**  
Soldering Iron



P.10

**FU-6002**  
Soldering Iron



P.10

## Soldering Iron

### All-Round Soldering Station & Accessories

**FX-888D**  
65 W



P.16

**FX-889**  
2-Port Type



P.16

**FX-8801**  
Soldering Iron M type (65 W)



P.19

**FX-8803**  
Soldering Gun (65 W)



P.19

**FX-8804**  
SMD Hot Tweezers (65 W)



P.19

**FX-8805**  
Soldering Iron L type (65 W)



P.19

### Heavy Duty Soldering Station

**FX-801**  
300 W



P.14

**FX-838**  
150 W



P.28

### High Performance Soldering Station & Accessory

**FX-951**  
70 W



P.22

**FX-950**  
70 W



P.22

**FM-2032**  
Micro Soldering Iron (48 W)



P.23

**FX-100**  
IH



P.26

**FX-1002**  
Micro Soldering Iron



P.27

### High Performance Rework Station & Accessories

**FM-203**  
2-Port Type



P.30

**FM-206**  
3-Port Type

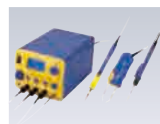

P.30

**FM-2027**  
Soldering Iron (70 W)



P.31

### High Performance Soldering Station & Accessory

**FM-2032**  
Micro Soldering Iron (48 W)

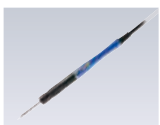

P.31

**FM-2022**  
SMD Hot Tweezers (140 W)



P.31

**FM-2023**  
Mini SMD Hot Tweezers (140 W)



P.31

**FM-2024**  
Desoldering Tool (70 W)



P.31

**FM-2029**  
Hot Air Pencil (140 W)



P.31

**FM-2030**  
Heavy Duty Soldering Iron (140 W)



P.31

### N<sub>2</sub> System

**FX-780**  
N<sub>2</sub> Generator



P.38

**FX-781**  
N<sub>2</sub> Generator



P.38

**FX-791**  
N<sub>2</sub> Flowmeter



P.38

**FX-8802**  
N<sub>2</sub> Soldering Iron (65 W)



P.39

**FM-2026**  
N<sub>2</sub> Soldering Iron (70 W)



P.39

**FM-2031**  
N<sub>2</sub> Soldering Iron (140 W)



P.39

**FM-2032**  
N<sub>2</sub> Micro Soldering Iron (48 W)



P.39

**FX-8302**  
N<sub>2</sub> Soldering Iron (150 W)

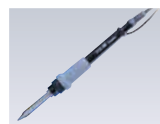

P.39

**FX-8003**  
N<sub>2</sub> Soldering Iron (260 W)



P.39

### Ceramic Heater Type

**FX-600**  
For Electronics Parts Soldering



P.42

**FX-601**  
For Heavy Duty Soldering



P.42

**DASH**



P.44

**PRESTO**



P.45

### Battery-Powered Type

**FX-901**



P.46

### Nichrome Heater Type

**RED**



P.47

**MG**  
Solder Feed Soldering Iron



P.47

## Soldering Pot

### Soldering Pot

**FX-301B**  
High Performance Type



P.48

**FX-300**  
High Performance Type



P.48

**96**



P.50

### Flow Soldering System

**485**



P.50



## Soldering-Related Equipment & Materials

### Tools for Lead and Wire

**FT-801**  
Thermal Wire Stripper



P.54

**153 & 154**  
Lead Cutter And Former



P.56

**155**  
Lead Cutter



P.56

**152B**  
Motor Drive



P.57

**DIPLINER**  
Lead Straightener

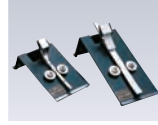

P.57

**106**  
Cutting Tool



P.55

### Self Feeder

**373**  
Self Feeder



P.52

**375**  
V-Groove Maker



P.51

**Tip Cleaner**  
FT-710



P.58

**Tip Polisher**  
FT-700 & FS-100



P.59

**Iron Holder & Reel Stand**  
Iron holder 611



P.60

**Vacuum Pick-Up Tool**  
392 Outlet-Powered Type

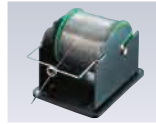

P.60

**393**  
Dropper Type



P.62

**394**  
Battery-Powered Type



P.62

**Flux Pen**  
FS-210

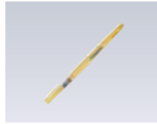

P.61

## Desoldering & Rework

### Heavy Duty Type

**FR-400**  
300 W



P.66

### High-Power Type

**FR-410**  
140 W



P.66

### Desoldering Tool & Wire

**FM-204**  
70 W



P.69

**FR-301**  
Portable Type



P.64

### SPPON

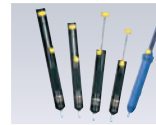

P.70

### WICK

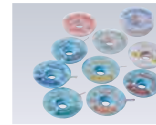

P.70

### Repair System

**FR-701**  
2-Port Type



P.80

### Rework System

**FR-702**  
4-Port Type



P.81

### Preheater

**FR-870B**  
IR Type (M-Size)

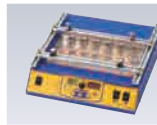

P.82

**FR-872**  
IR Type (L-Size)

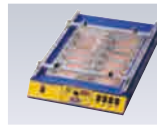

P.82

**FR-830**  
Hot Air Type

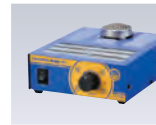

P.82

### SMD Rework Station

**FR-810B**



P.72

**FR-811**



P.72

**851**



P.71

## Smoke Absorber

### Air-Purifying Type

**FA-430**  
HEPA Filter



P.84

**FA-431**  
Cost Performance Filter



P.85

### Desktop Type

**FA-400**



P.87

**490**



P.88

### Line Production System

**494**



P.89

## Static Control

### Static Eliminator

**FE-510**



P.90

### Wrist Strap

**442B**



P.91

## Tester & Meter

### Wrist Strap Tester

**498**



P.91

### Footwear Tester

**FG-460**

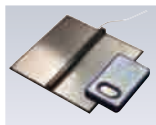

P.92

### Thermometer

**FG-102**



P.94

**FG-100**



P.96

### Soldering Tester

**FG-101**



P.96

### Static Level Meter

**FG-450**



P.93

### Heating Gun

**FV-310**



P.98

### Glue Gun

**804**



P.100

# HAKKO Soldering Iron Lineup

		FX-888D	FX-889	FX-801	FX-838	FX-100	FX-951	FX-950	
									
Types		All-Round		Heavy Duty		IH	High Performance		
Specifications	Power consumption	70 W	135 W	300 W	158 W	25 W (85 W)	75 W	75 W	
	Power consumption of Handpiece	65 W	65 W x 2 port	260 W	150 W	—	70 W	70 W	
	Temperature Range	50 to 480°C	50 to 480°C	50 to 500°C	200 to 500°C	350°C/400°C/450°C	200 to 450°C	200 to 450°C	
	Soldering Tip	T18 series	T18 series	T33 series	T20 series	T31 series	T12 series	T12 series	
Applicable Standard	Lead Free Suggestible	●	●	●	●	●	●	●	
	ESD Safe	●	●	●	●	●	●	●	
	RoHS Suggestible	●	●	●	●	●	●	●	
Accessories	Micro Soldering Iron connectable					●	●		
	N <sub>2</sub> Micro Soldering Iron connectable						●		
	N <sub>2</sub> Soldering Iron connectable	●	●		●		●	●	
	N <sub>2</sub> Heavy Duty Soldering Iron connectable			●	●				
	Self Feeder connectable	●	●	●	●	●	●	●	
	SMD Hot Tweezers connectable	●	●						
	Desoldering Iron connectable								
	Hot Air Handpiece connectable								
Function	Auto Shutoff Function: When a set time passed, the function stops to supply power to the heating element.								
				●	●	●	●		
	Auto Sleep Function: When a set time passed, the tip temperature decreases to a set lower temperature.								
				●	●	●	●	●	Option
	Lock Function: Lockable by password, control card or lock key.								
		Password	Password	Password	Control card	Password	Control card	Lock key	
	Lower Temperature Error Alert: When the temperature drops below a set limit, an error is displayed and the buzzer sounds.								
				●	●		●		
	Offset Temperature Function: Temperature offsettable by analog, digital or adjustment mode.								
	Adjustment mode	Adjustment mode	Digital	Digital		Digital	Manual		
Preset Temperature Function: The function allows to input several frequently-used temperatures and recall with one push of a button.									
	●	●	●	●					



# Auto-Soldering System

**HAKKO** FU-500 **ESD SAFE**  
FEEDER CONTROLLER  
**HAKKO** FU-600 **ESD SAFE**  
SOLDERING STATION

**HAKKO** FU-601 **ESD SAFE**  
SOLDERING STATION

## Auto-Soldering System

Tip not included

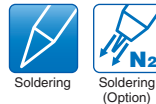

### HAKKO FU-500 **ESD SAFE**

- Accurate solder feeding
- Supports solder diameters of 0.3 mm and up to 1.6 mm
- Solder feed error detection
- Equipped with countermeasures against solder ball splash as standard

### HAKKO FU-600/601 **ESD SAFE**

- Easy tip replacement
- High performance composite tip
- Six presets tip-temperature function
- 300 W of ultra-high power (FU-601)

### Packing List

<b>FU-500</b>	Main unit, Feeder unit, Solder reel stand, Feeder cable, Tube unit, Power cord, Instruction manual
<b>FU-600</b> <b>FU-601</b>	Station, Handpiece (FU-6001 or FU-6002), Iron unit fixing assembly, Tip adjustment jig unit, Iron cable, Heat resistant pad, Connecting cable, Power cord, Flux protector, Feeder unit attachment screw, Instruction manual

### Specifications

Model No.	FU-500	
Power consumption	35 W	
Compatible solder diameters	0.3 mm, 0.5 mm, 0.6(0.65) mm, 0.8 mm, 1 mm, 1.2 mm, 1.6 mm	
Dimensions	145 mm (W) × 100 mm (H) × 230 mm (D)	
Weight	2.3 kg	

Model No.	FU-600	FU-601
Power consumption	140 W	140 W/300 W
Temperature range	50 to 500°C	
Preset temperature	6 settings	
Dimensions	145 mm (W) × 102 mm (H) × 210 mm (D)	145 mm (W) × 107 mm (H) × 211 mm (D)
Weight	2.8 kg	4 kg

### Soldering Iron

Model No.	FU-6001	FU-6002
Total length	186 mm with 2.4XD tip for TX1 194 mm with 4XD tip for TX2	160 mm with 2.4XD tip for TX1 168 mm with 4XD tip for TX2
Weight*	163 g with 2.4XD tip for TX1 171 g with 4XD tip for TX2	165 g with 2.4XD tip for TX1 173 g with 4XD tip for TX2

\* With iron unit fixing assembly

### Replacement Parts (Optional)

\* The accessories are required for initial set-up, such as a solder feed pulley unit, solder-feed guide set, and teflon tube are not included. They must be ordered separately and adapted to use with the soldering iron and solder wire diameter.

Part No.	Name	Remarks
BX1000	Solder feed pulley unit/0.3 mm	
BX1001	Solder feed pulley unit/0.5 mm	
BX1002	Solder feed pulley unit/0.6 mm	
BX1003	Solder feed pulley unit/0.8 mm	
BX1004	Solder feed pulley unit/1 mm	
BX1005	Solder feed pulley unit/1.2 mm	
BX1006	Solder feed pulley unit/1.6 mm	
BX1007	Solder feed guide set/0.3 mm	
BX1008	Solder feed guide set/0.5 to 1 mm	
BX1009	Solder feed guide set/1.2 to 1.6 mm	
BX1010	Teflon tube/0.3 mm (set of 10)	
BX1011	Teflon tube/0.5 to 0.6 mm (set of 10)	
BX1012	Teflon tube/0.8 mm (set of 10)	
BX1013	Teflon tube/1 mm (set of 10)	
BX1014	Teflon tube/1.2 mm (set of 10)	
BX1015	Teflon tube/1.6 mm (set of 10)	
BX1016	Tube unit/0.3 to 1 mm	
BX1017	Tube unit/1.2 to 1.6 mm	
BX1027	Flux protector	
BX1023	Adapter assembly for TX1	
BX1029	Adapter assembly A for TX2	
BX1024	Nozzle assembly <A> for TX1	
BX1025	Nozzle assembly <B> for TX1	
BX1026	Nozzle assembly <C> for TX1	
BX1030	Nozzle assembly <D> for TX2	
BX1031	Nozzle assembly <E> for TX2	
CX1000	Slide unit	
CX1001	Slide unit for drag soldering	
CX1002	Temperature probe	
CX1003	Cleaner	



**Features**

300 W of ultra-high power FU-601 is added to Auto-Soldering System.



The top side

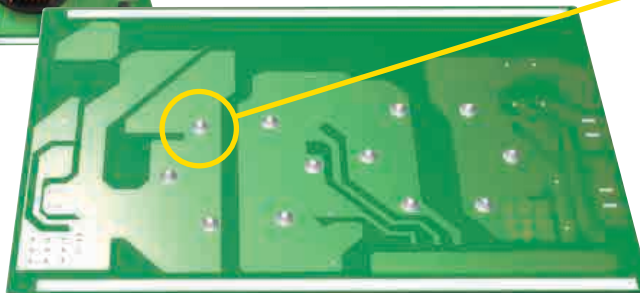

The reverse side

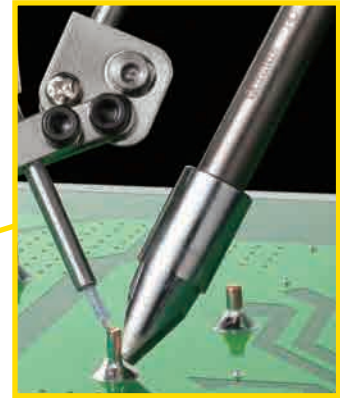

**Compact TX1 series can provide excellent thermal recovery characteristic despite its compact design.**

140 W TX1 for FU-600 and FU-601



300 W TX2 for FU-601



**Accurate solder feeding**

The solder feed unit is closer to the iron.

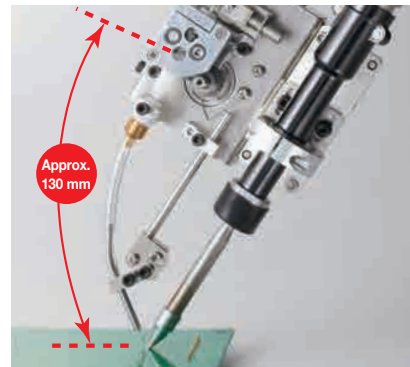

**Countermeasures against solder ball splash**

Equipped with a mechanism that perforates into the solder wire as standard.

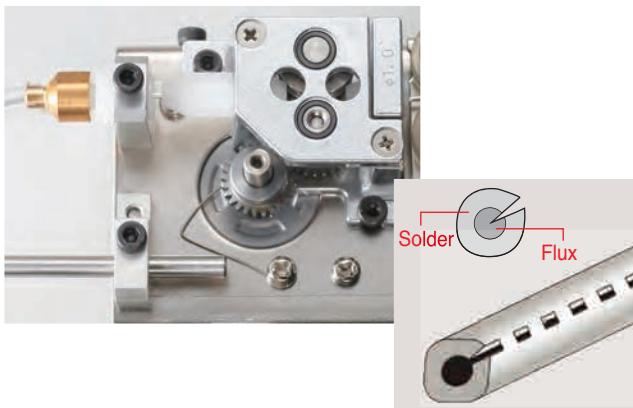

**Easy tip replacement**

The position of the tip end can be easily adjusted using the tip adjustment jig unit included with FU-600 and FU-601.

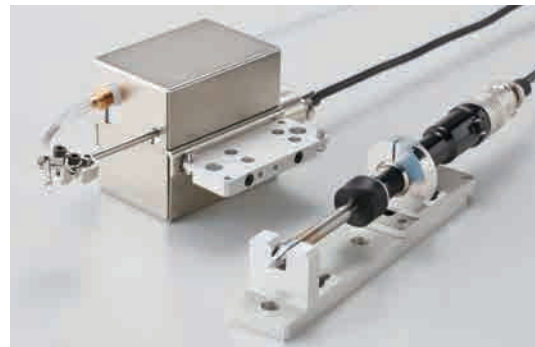

# Auto-Soldering System

## More Features

### Solder feed error detection

With an optical sensor for solder movement, FU-500 can detect solder clogging, slipping and the end of the roll.

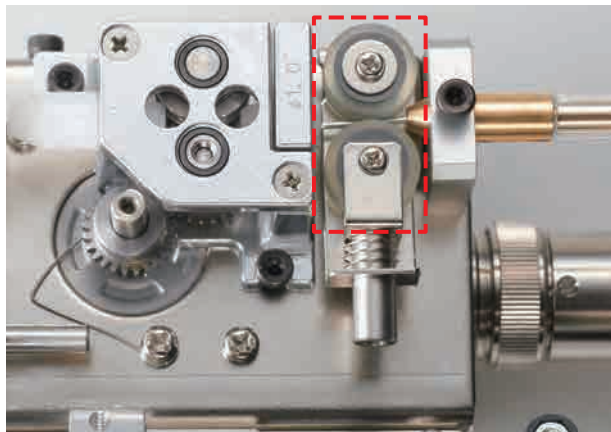

### Two types of soldering irons

Straight iron FU-6001

L-shaped iron FU-6002



## Optional Parts & Accessories

### Slide unit

This unit allows the soldering unit vertical movement with external air.

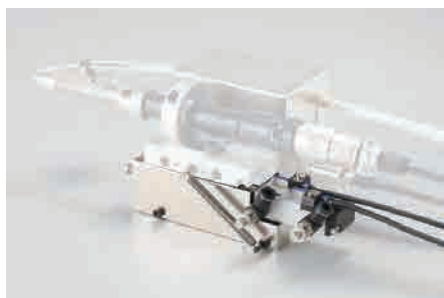

### Slide unit (for drag soldering)

This unit absorbs height variation.



### Tip cleaner

The brush removes excess solder and flux carbides.



### Temperature probe

The probe makes tip temperature measurement easy.



### N<sub>2</sub> adapter assembly

Simply attach the optional N<sub>2</sub> adapter to the iron and install a nozzle assembly that matches the tip to perform N<sub>2</sub> soldering.

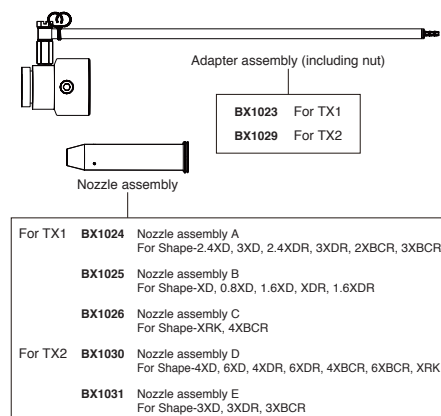

**Optional Tips for FU-600 & FU-601**

Unit: mm

<p><b>TX1-XD Shape-XD</b></p>	<p><b>TX1-XD08 Shape-0.8XD</b></p>	<p><b>TX1-XD16 Shape-1.6XD</b></p>	<p><b>TX1-XD24 Shape-2.4XD</b></p>	<p><b>TX1-XD3 Shape-3XD</b></p>
<p><b>TX1-XBCR2 Shape-2XBCR</b></p>	<p><b>TX1-XBCR3 Shape-3XBCR</b></p>	<p><b>TX1-XBCR4 Shape-4XBCR</b></p>	<p><b>TX1-XDR Shape-XDR</b></p>	
<p><b>TX1-XDR16 Shape-1.6XDR</b></p>	<p><b>TX1-XDR24 Shape-2.4XDR</b></p>	<p><b>TX1-XDR3 Shape-3XDR</b></p>	<p><b>TX1-XRK Shape-XRK</b></p>	

**Optional Tips for FU-601**

Unit: mm

<p><b>TX2-XD3 Shape-3XD</b></p>	<p><b>TX2-XD4 Shape-4XD</b></p>	<p><b>TX2-XD6 Shape-6XD</b></p>	<p><b>TX2-XBCR3 Shape-3XBCR</b></p>
<p><b>TX2-XBCR4 Shape-4XBCR</b></p>	<p><b>TX2-XBCR6 Shape-6XBCR</b></p>	<p><b>TX2-XDR3 Shape-3XDR</b></p>	<p><b>TX2-XDR4 Shape-4XDR</b></p>
<p><b>TX2-XDR6 Shape-6XDR</b></p>	<p><b>TX2-XRK Shape-XRK</b></p>		

# Heavy Duty Soldering Station

## HAJKO FX-801 ESD SAFE SOLDERING STATION

### Heavy Duty Soldering Station Digital

Tip not included



- Super power 300 W
- Best suited for soldering P.W.B. with high heat capacity and high heat dissipation property

### Optional Tips for FX-8002

Unit: mm

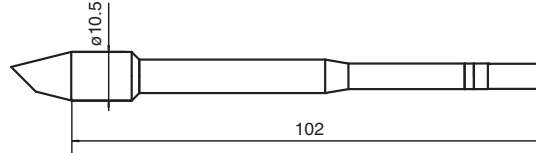

T33-BC2 Shape-2BC

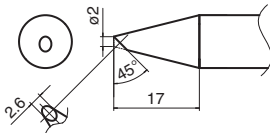

T33-BC3 Shape-3BC

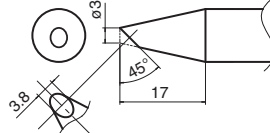

T33-BC4 Shape-4BC

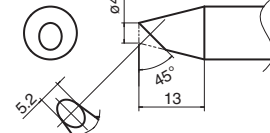

T33-BC5 Shape-5BC

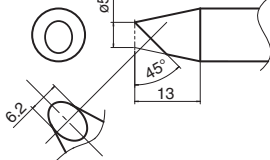

T33-BC6 Shape-6BC

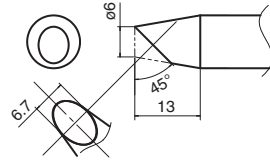

T33-D24 Shape-2.4D

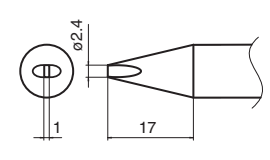

T33-D32 Shape-3.2D

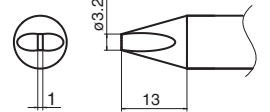

T33-D5 Shape-5D

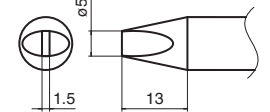

T33-D6 Shape-6D

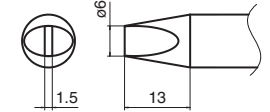

T33-1610

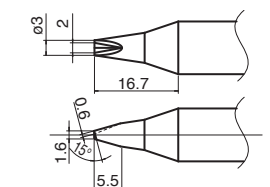

T-33-1611

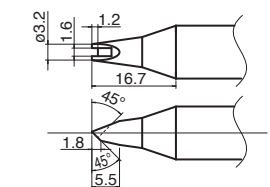



## Features

### Make the impossible possible with Super Power of 300 W Heater

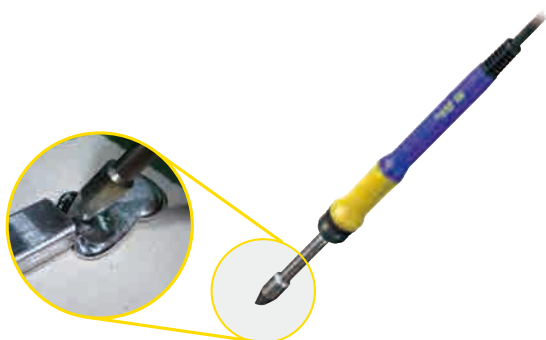

Check out the powerful performance of FX-801 easily melting a bar solder.

[http://www.hakko.com/mov\\_e\\_fx801\\_feature1](http://www.hakko.com/mov_e_fx801_feature1)



QR code

**Compact and lightweight (50 g) for heavy duty 300 W iron**  
The same weight as the iron part of FX-838, 150 W soldering station, for operator's comfort and better workability.

### Large LED display enables easy viewing and operation.



#### Handles on unit body

Handles on unit body make it easy to carry.

#### Preset mode

Up to 6 settings can be preset and easily called up by Up/Down buttons.

#### Password function

Settings can be locked from unnecessary changes by password function.



Selectable alphabets for password

### Connectable with N<sub>2</sub> soldering iron

To improve solder wettability and spreadability

**HAKKO** **FX-8003** **ESD SAFE**  
SOLDERING IRON

## N<sub>2</sub> Soldering Iron

Tip not included

Please see the optional tips on P.41.



For further details, see the N<sub>2</sub> system (P.38 & P.39).

## Packing List

<b>FX-801</b>	Station, Handpiece (FX-8002), Heat resistant pad, Power cord, Connecting cable, Iron holder (with cleaning wire), Instruction manual
<b>FX-8003</b>	Handpiece, Instruction manual

## Specifications

<b>Model No.</b>	FX-801
Power consumption	300 W
Temperature range	50 to 500°C
Temperature stability	±5°C at idle temperature

### Station

Output voltage	AC 29 V
Dimensions	145 (W) × 107 (H) × 211 (D) mm
Weight	3.9 kg

### Soldering Iron

Power consumption	260 W (29 V)
Tip to ground resistance	<2 Ω
Tip to ground potential	<2 mV
Heating element	Composite heater
Cord length	1.2 m
Total length*	228 mm (with 4BC tip)
Weight*	50 g (with 4BC tip)

\* Without cord

<b>Model No.</b>	FX-8003
Power consumption	260 W (29 V)
Temperature range	50 to 500°C
Tip to ground resistance	<2 Ω
Tip to ground potential	<2 mV
Heating element	Composite heater
Cord length	1.2 m
Total length*	253 mm (with 4BC tip)
Weight*	65 g (with 4BC tip and nozzle assembly A)

\* Without cord

# All-Round Soldering Station

## HAJKO FX-888D SOLDERING STATION ESD SAFE

### All-Round Soldering Station Digital

Tip included

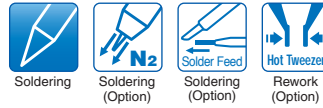

- Features Adjustment mode, Preset mode, and Password function
- Separable tip/heater design provides superior cost performance.
- L type (Large type) soldering iron FX-8805 is added to the lineup.

## HAJKO FX-889 SOLDERING STATION ESD SAFE

### 2-Port All-Round Soldering Station Digital

Tip included

\* 1 piece of FX-8801 is included as standard.

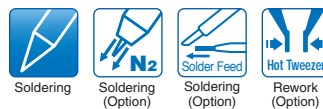

- All the user-friendly functions are succeeded from FX-888D.
- Two applications can be active at the same time.
- Applicable to all the options, N<sub>2</sub> soldering iron, Soldering gun, SMD Hot Tweezers, and L type (Large type) soldering iron.

## Common features

### Strict temperature management

#### ● Digital display

FX-888D's and FX-889's digital display makes it easy to check the set temperature at a glance.

#### ● Password function

Settings can be locked using a password to prevent them from being changed unexpectedly.

#### ● Preset mode

Simply select the desired temperature from a selection of preset temperatures registered in advance. (Up to 5 preset temperatures can be registered.)

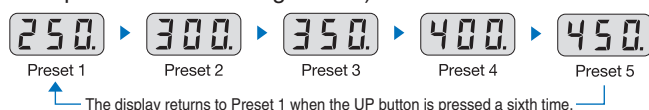

#### ● Adjustment mode

With adjustment mode, what used to be a troublesome procedure is now as simple as entering the measured tip temperature in FX-888D and FX-889.

#### ● FX-888D and FX-889 deliver excellent thermal recovery by using T18 and T19 series tips for their terrific heat conductivity.

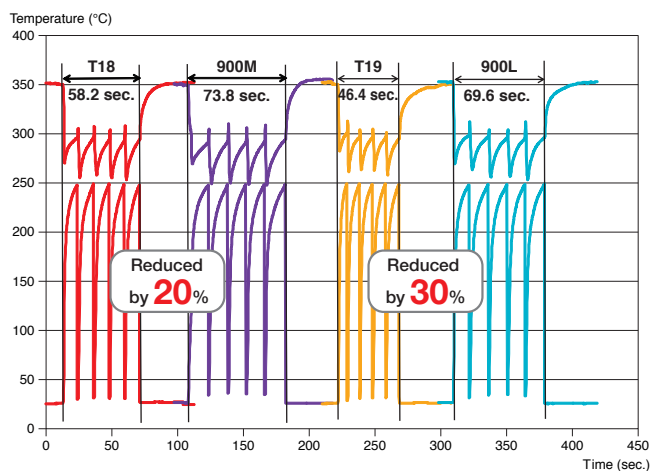

### Test criteria

Measurement method	Thermocouples are mounted on the tip and the soldered portion on the board, and the time until the soldered portion reaches 250°C is measured for 5 points.
Board	Paper phenol copper board
Component used	Terminal
Tip shape	Shape-2.4D
Temperature setting	350°C
Solder	Lead-free solder (Sn/Ag/Cu), diameter: 0.5 mm



Measuring the tip temperature with a tip thermometer (FG-100)

## Packing List

FX-888D	Station, Handpiece (FX-8801), Iron holder, Instruction manual
FX-889	Station, Handpiece (FX-8801), Power cord, Dual Iron Holder, Color band (qty 2), Instruction Manual

## Specifications

Model No.	FX-888D	FX-889
Power consumption	70 W	135 W
Temperature range	50 to 480°C	50 to 480°C
Temperature stability	±1°C at idle temperature (when set to 200 to 480°C)	

### Station

Output voltage	AC 26 V	AC 26 V
Dimensions	100 (W) × 120 (H) × 120 (D) mm	157 (W) × 121 (H) × 149 (D) mm
Weight	1.2 kg*	2.1 kg

### Soldering Iron

Power consumption	65 W (26 V)	65 W (26 V)
Tip to ground resistance	<2 Ω	<2 Ω
Tip to ground potential	<2 mV	<2 mV
Heating element	Ceramic heater	Ceramic heater
Standard tip	Shape-B (No.T18-B)	Shape-B (No.T18-B)
Cord length	1.2 m	1.2 m
Total length*	217 mm (with B tip)	222 mm (with B tip)
Weight*	46 g (with B tip)	52 g (with B tip)

\* Without cord

# All-Round Soldering Station and Accessories

## Features of FX-889

### User-Friendly Design

#### ● Space-saving design

The reduced foot print is smaller than 2 of FX-888D and its iron holder. Efficient setup is available even on smaller workbench.

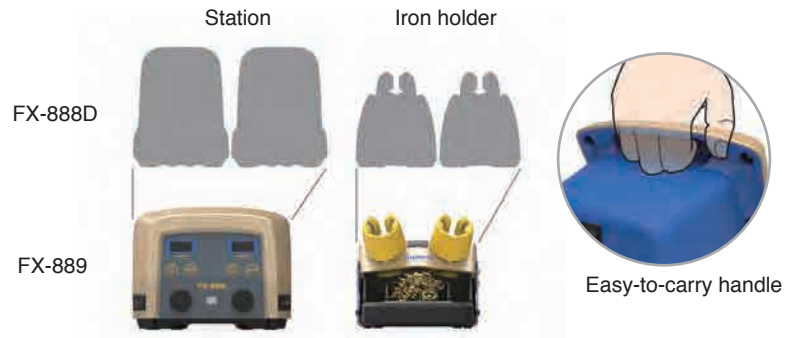

#### ● Power-saving design

Independent switches cut the power for each iron when not in use. Power-saving design minimizes standby electricity.

#### ● Superior operability

Four buttons were symmetrically placed at the both sides on the front panel. The two buttons on each side allow simple and intuitive operation.

A color band can be attached to the handle, and this makes it possible to see at a glance which side it is connected to. (2 pieces of color band are included as the standard accessories.)



#### ● Rich functions of iron holder

- Convenient pockets to stock soldering tips
- Three different ways for tip cleaning with provided cleaning tools
- Simple and easy cleaning of iron holder inside by removing holder base

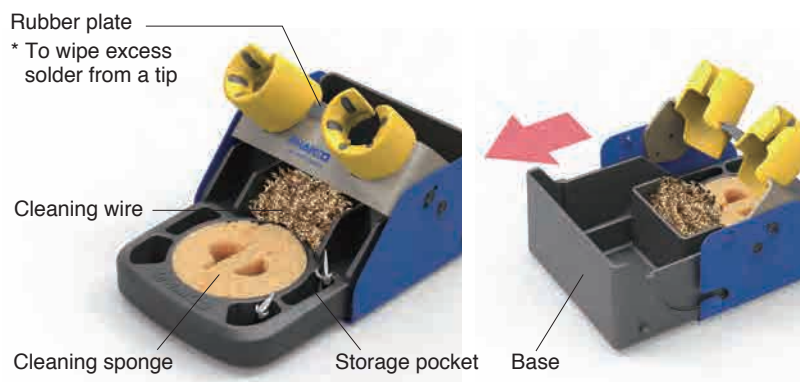



**HAKO FX-8801** ESD SAFE  
SOLDERING IRON**Soldering Iron M type**

Tip included

**HAKO FX-8802** ESD SAFE  
SOLDERING IRON**N<sub>2</sub> Soldering Iron**

Tip included

**HAKO FX-8803** ESD SAFE  
SOLDERING GUN**Soldering Gun**

Tip included

**HAKO FX-8804** ESD SAFE  
SMD HOT TWEEZER**SMD Hot Tweezers**

Tip included

**HAKO FX-8805** ESD SAFE  
SOLDERING IRON**Soldering Iron L type**

Tip included

**Specifications**

Model No.	FX-8801
Power consumption	65 W (26 V)
Temperature range	50 to 480°C
Tip to ground resistance	<2 Ω
Tip to ground potential	<2 mV
Heating element	Ceramic heater
Standard tip	Shape-B (No.T18-B)
Cord length	1.2 m
Total length*	217 mm (with B tip)
Weight*	46 g (with B tip)

\* Without cord

Model No.	FX-8802
Power consumption	65 W (26 V)
Temperature range	50 to 480°C
Tip to ground resistance	<2 Ω
Tip to ground potential	<2 mV
Heating element	Ceramic heater
Standard tip	Shape-B (No.T18-B)
Cord length	1.2 m
Total length**	190 mm (with B tip)
Weight**	59 g (with B tip and nozzle assembly A)

\* Use this N<sub>2</sub> soldering iron below 450°C.

\*\* Without cord and tube

Model No.	FX-8803
Power consumption	65 W (26 V)
Temperature range	50 to 480°C
Tip to ground resistance	<2 Ω
Tip to ground potential	<2 mV
Heating element	Ceramic heater
Standard tip	Shape-3C pre-tinned surface 45° (No.T18-CF3)
Standard guide nozzle	ø1 mm
Usable solder diameter	0.6, 0.8, 1, 1.2, 1.6 mm
Cord length	1.1 m
Dimensions	170 (W) × 180 (H) × 23 (D) mm
Weight*	207 g

\* Without cord

Model No.	FX-8804
Power consumption	65 W (26 V)
Temperature range	200 to 400°C
Tip to ground resistance	<2 Ω
Tip to ground potential	<2 mV
Heating element	Ceramic heater
Standard tip	Shape-2L (No. A1378) 2 pcs/set
Cord length	1.2 m
Total length**	186 mm
Weight**	93 g

\* The recommended (process) temperature is from 200°C to 400°C while setting temperature range of FX-888D is from 50°C to 480°C.

\*\* Without cord

Model No.	FX-8805
Power consumption	65 W (26 V)
Temperature range	50 to 480°C
Tip to ground resistance	<2 Ω
Tip to ground potential	<2 mV
Heating element	Ceramic heater
Standard tip	Shape-B (No.T19-B)
Cord length	1.2 m
Total length*	222 mm (with B tip)
Weight*	52 g (with B tip)

\* Without cord

# All-Round Soldering Station and Accessories

## Packing List

<b>FX-8801</b>	Handpiece, Instruction Manual
<b>FX-8802</b>	Handpiece, Shield plate, Instruction manual
<b>FX-8803</b>	Handpiece, Instruction manual
<b>FX-8804</b>	Handpiece, Caution label, Heat resistant pad, Instruction manual
<b>FX-8805</b>	Handpiece, Instruction Manual

NOTE: The soldering iron cannot be used as a standalone device.

## Option

### FX-8803

Part No.	Name	Specifications
C1437	Iron holder (with cleaning sponge)	-

### FX-8804

Part No.	Name	Specifications
FH800-04BY	Iron holder (with cleaning sponge)	Blue & yellow

### FX-8801 & FX-8805

Part No.	Name	Specifications
B5122	Tip enclosure	With nut, required when converting from FX-8801 to FX-8805
B3730	Nut and tip enclosure	Required when converting from FX-8805 to FX-8801

## Replacement Tips for FX-8801 and FX-8803

Unit: mm

<p>Applicable for FX-8803</p> <p><b>T18-B Shape-B</b></p>	<p>Applicable for FX-8803</p> <p><b>T18-SB Shape-SB</b></p>	<p><b>T18-BR02 Shape-0.2BR</b></p>	<p><b>T18-BL Shape-BL</b></p>	<p><b>T18-C05 Shape-0.5C</b></p>
<p>Applicable for FX-8803</p> <p><b>T18-C08 Shape-0.8C</b></p>	<p>Applicable for FX-8803 (Only C1)</p> <p><b>T18-C1 Shape-1C</b> <b>T18-CF1*</b></p>	<p><b>T18-CF15* Shape-1.5C</b></p>	<p>Applicable for FX-8803</p> <p><b>T18-C2 Shape-2C</b> <b>T18-CF2*</b></p>	<p>Applicable for FX-8803</p> <p><b>T18-CSF25* Shape-2.5CS</b></p>
<p>Applicable for FX-8803</p> <p><b>T18-C3 Shape-3C</b> <b>T18-CF3*</b></p>	<p>Applicable for FX-8803</p> <p><b>T18-C4 Shape-4C</b> <b>T18-CF4*</b></p>	<p>Applicable for FX-8803</p> <p><b>T18-C5 Shape-5C</b></p>	<p>Applicable for FX-8803</p> <p><b>T18-K Shape-K</b></p>	<p>Applicable for FX-8803</p> <p><b>T18-D08 Shape-0.8D</b></p>
<p>Applicable for FX-8803</p> <p><b>T18-D12 Shape-1.2D</b></p>	<p>Applicable for FX-8803</p> <p><b>T18-D16 Shape-1.6D</b></p>	<p>Applicable for FX-8803</p> <p><b>T18-D24 Shape-2.4D</b></p>	<p>Applicable for FX-8803</p> <p><b>T18-D32 Shape-3.2D</b></p>	<p><b>T18-DL12 Shape-1.2DL</b></p>
<p><b>T18-DL2 Shape-2DL</b></p>	<p><b>T18-DL32 Shape-3.2DL</b></p>	<p><b>T18-S3 Shape-S3</b></p>	<p>Applicable for FX-8803</p> <p><b>T18-S4 Shape-S4</b></p>	<p><b>T18-S6 Shape-S6</b></p>
<p>Applicable for FX-8803</p> <p><b>T18-S9 Shape-S9</b></p>	<p>Applicable for FX-8803</p> <p><b>T18-I Shape-I</b></p>			

\* These tips are tinned on the soldering surface only.

### Replacement Tips and Nozzles for FX-8802

Please see the replacement tips on P.40

### Replacement Tips for FX-8804

#### For Chip Component

Part No.	Name	Size of A (B)	Tip Shape
A1577	Tip/CHIP 0.5L	0.5 mm	
A1379	Tip/CHIP 1L	1 mm	
A1378	Tip/CHIP 2L	2 mm	
A1388	Tip/CHIP 0.5C	1.5 (0.5) mm	
A1389	Tip/CHIP 0.5I	R0.25 mm	
A1576	Tip/CHIP 2.6C	2.6 mm	

#### For SOP Component

Part No.	Name	Size of A	Tip Shape
A1390	Tip/SOP 4L	4 mm	
A1391	Tip/SOP 6L	6 mm	
A1380	Tip/SOP 8L	8 mm	
A1381	Tip/SOP 10L	10 mm	
A1382	Tip/SOP 13L	13 mm	
A1392	Tip/SOP 15L	15 mm	
A1383	Tip/SOP 18L	18 mm	
A1384	Tip/SOP 20L	20 mm	
A1385	Tip/SOP 25L	25 mm	

### Replacement Tips for FX-8805

Unit: mm

<b>T19-B Shape-B</b> 	<b>T19-B2 Shape-2B</b> 	<b>T19-C3 Shape-3C</b> 	<b>T19-C4 Shape-4C</b> 	<b>T19-C65 Shape-6.5C</b> 
<b>T19-D24 Shape-2.4D</b> 	<b>T19-D32 Shape-3.2D</b> 	<b>T19-D5 Shape-5D</b> 	<b>T19-D65 Shape-6.5D</b> 	<b>T19-I Shape-I</b> 

# High Performance Soldering Station

## HAKKO FX-951 SOLDERING STATION ESD SAFE

### High Performance Soldering Station Digital

Tip not included

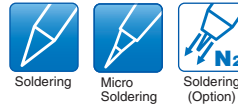

- Compact high-power thermally-controlled soldering iron
- Informs you of errors by a warning buzzer or display

## HAKKO FX-950 SOLDERING STATION ESD SAFE

### High Performance Soldering Station Analog

Tip not included

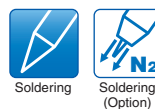

- Analog type high-power thermally-controlled soldering iron
- “Lock key” can lock the temperature setting.
- Informs you of various errors by a lamp

## Features

### Thermal recovery graph (comparison of HAKKO products)

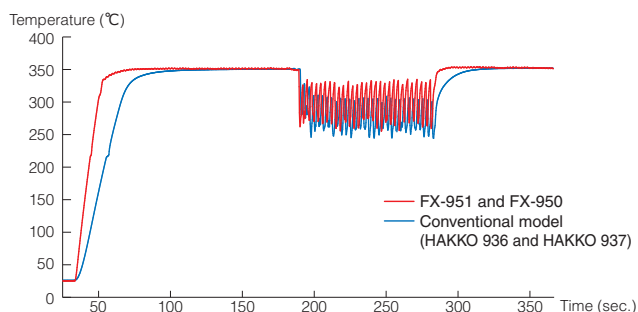

### Test criteria

Measurement method	A thermocouple is mounted on the tip and the tip temperature is measured when soldering $\phi 1.6 \text{ mm} \times 5 \text{ mm}$ solder to paper phenol copper board once every 3 seconds.
Board	Paper phenol copper board.
Temperature setting	350°C
Solder	Lead-free solder (Sn/Ag/Cu), diameter: 1.6 mm $\times$ 5 mm

### Connectable with micro soldering iron

For micro soldering applications under a microscope

## HAKKO FM-2032 ESD SAFE

### Micro Soldering Iron

Tip not included

Please see the optional tips on P.36.



N<sub>2</sub> Soldering is available with optional parts (P.39 & P.41).

### Connectable with N<sub>2</sub> soldering iron

To improve solder wettability and spreadability

## HAKKO FM-2026 ESD SAFE

### N<sub>2</sub> Soldering Iron

Tip not included

Please see the optional tips on P.40.



For further details, see the N<sub>2</sub> system (P.38 & P.39).

### Composite tip

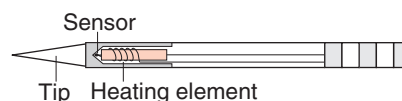

The composite tip with an integrated heating element and sensor offers superior thermal responsivity and thermal recovery.

### Specifications

Model No.	FX-951	FX-950
Power consumption	75 W	
Temperature range	200 to 450°C	
Temperature stability	±5°C at idle temperature	

### Station

Output voltage	AC 24 V
Dimensions	FX-951: 80 (W) $\times$ 130 (H) $\times$ 131 (D) mm FX-950: 80 (W) $\times$ 118 (H) $\times$ 138 (D) mm
Weight	1.2 kg

### Soldering Iron

Power consumption	70 W (24 V)
Tip to ground resistance	<2 $\Omega$
Tip to ground potential	<2 mV
Heating element	Composite heater
Cord length	1.2 m
Total length*	188 mm (with 2.4D tip)
Weight*	30 g (with 2.4D tip)

\* Without cord

Model No.	FM-2032	FM-2026
Power consumption	48 W (24 V)	70 W (24 V)
Temperature range	200 to 450°C	
Tip to ground resistance	<2 $\Omega$	
Tip to ground potential	<2 mV	
Heating element	Composite heater	
Cord length	1.3 m	1.2 m
Total length	170 mm* (with 1D tip)	205 mm** (with 2.4D tip)
Weight	14 g* (with 1D tip)	45 g** (with 2.4D tip and nozzle assembly C)

\* Without cord \*\* Without cord and tube \*\*\* Use FM-2026 below 400°C.

### Packing List

FX-951	Station, Handpiece (FM-2028), Control card, Power cord, Connecting cable, Heat resistant pad, Iron holder, Instruction manual
FX-950	Station, Handpiece (FM-2028), Lock key, Heat resistant pad, Iron holder, Instruction manual
FM-2032 (Conversion kit)	Handpiece, Heat resistant pad, Iron holder, Connecting cable, Instruction manual
FM-2026 (Conversion kit)	Handpiece, Sleeve cover, Sleeve assembly (yellow), Heat resistant pad, Iron holder, Connecting cable, Instruction manual







# High Performance Soldering Station

## Optional Tips for FM-2028

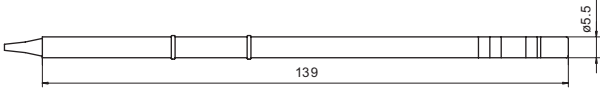
Unit: mm

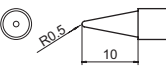
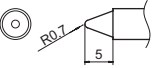
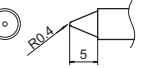
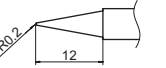
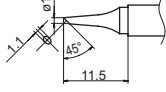
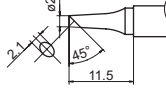
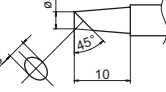
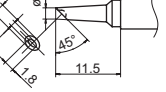
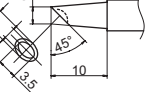
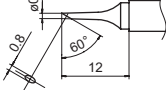
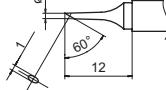
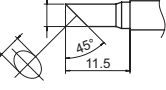
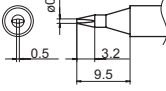
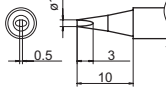
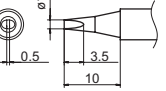
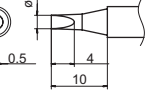
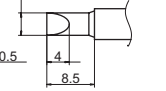
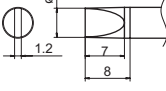
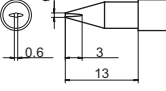
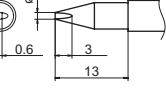
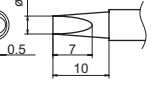
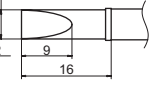
### Standard type

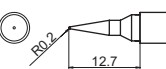
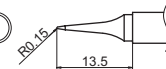
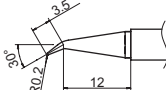
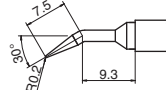
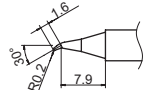
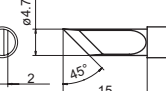
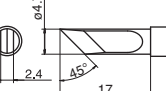
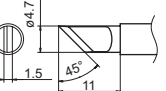
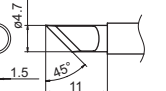
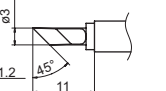
					
<b>B</b>	<b>T12-B Shape-B</b> 	<b>T12-B2 Shape-0.5B</b> 	<b>T12-B3 Shape-0.7B</b> 	<b>T12-B4 Shape-0.4B</b> 	<b>T12-BL Shape-BL</b> 
<b>BC</b>	<b>T12-BC1 Shape-1BC T12-BCF1*</b> 	<b>T12-BC2 Shape-2BC T12-BCF2*</b> 	<b>T12-BC3 Shape-3BC T12-BCF3*</b> 	<b>T12-BCM2 Shape-2BC Bevel with indent</b> 	<b>T12-BCM3 Shape-3BC Bevel with indent</b> 
<b>C</b>	<b>T12-C08 Shape-0.8C</b> 	<b>T12-C1 Shape-1C</b> 	<b>T12-C4 Shape-4C T12-CF4*</b> 		
<b>D</b>	<b>T12-D08 Shape-0.8D</b> 	<b>T12-D12 Shape-1.2D</b> 	<b>T12-D16 Shape-1.6D</b> 	<b>T12-D24 Shape-2.4D</b> 	<b>T12-D4 Shape-4D</b> 
	<b>T12-D52 Shape-5.2D</b> 	<b>T12-DL08 Shape-0.8DL</b> 	<b>T12-DL12 Shape-1.2DL</b> 	<b>T12-DL32 Shape-3.2DL</b> 	<b>T12-DL52 Shape-5.2DL</b> 
<b>I</b>	<b>T12-I Shape-I</b> 	<b>T12-IL Shape-IL</b> 	<b>T12-ILS Shape-ILS</b> 		
<b>J</b>	<b>T12-J02 Shape-0.2J</b> 	<b>T12-JL02 Shape-0.2JL</b> 	<b>T12-JS02 Shape-0.2JS</b> 		
<b>K</b>	<b>T12-K Shape-K</b> 	<b>T12-KF Shape-KF</b> 	<b>T12-KL Shape-KL</b> 	<b>T12-KR Shape-KR</b> 	<b>T12-KU Shape-KU</b> 

\* These tips are tinned on the soldering surface only.

### Concave type

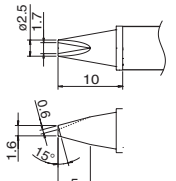
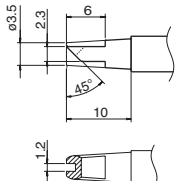
<b>T12-1610</b> 	<b>T12-1612</b> 
--	--

SMD type

Quad	T12-1201 Quad 13.6 x 8.5 	T12-1202 Quad 10.3 x 10.3 	T12-1203 Quad 12.8 x 12.8 	T12-1204 Quad 17.9 x 17.9 	T12-1205 Quad 23.4 x 17.3 
	T12-1206 Quad 22.5 x 16.5 	T12-1207 Quad 15.5 x 15.5 	T12-1208 Quad 15.8 x 15.8 	T12-1209 Quad 8.4 x 8.4 	
Tunnel	T12-1001 Tunnel 5.1 x 4.6 	T12-1002 Tunnel 5.1 x 10.4 	T12-1003 Tunnel 9.5 x 18.3 	T12-1004 Tunnel 9.5 x 15.8 	T12-1005 Tunnel 9.5 x 13.2 
	T12-1006 Tunnel 6.9 x 11.4 	T12-1007 Tunnel 7.9 x 18.8 	T12-1008 Tunnel 19.5 x 10.2 	T12-1009 Tunnel 13.4 x 20.5 	T12-1010 Tunnel 19.5 x 12 
Spatula	T12-1401 Spatula 10.4 	T12-1402 Spatula 15.7 	T12-1403 Spatula 21.2 	T12-1404 Spatula 25 	T12-1405 Spatula 32 
	T12-1406 Spatula 40 				

Long life type

T12-BZ Shape-B (Z) 	T12-B2Z Shape-0.5B (Z) 	T12-BC1Z Shape-1BC (Z) T12-BCF1Z* 	T12-BC2Z Shape-2BC (Z) T12-BCF2Z* 	T12-BC3Z Shape-3BC (Z) T12-BCF3Z* 
T12-C4Z Shape-4C (Z) T12-CF4Z* 	T12-D12Z Shape-1.2D (Z) 	T12-D16Z Shape-1.6D (Z) 	T12-D24Z Shape-2.4D (Z) 	T12-D4Z Shape-4D (Z) 
T12-KFZ Shape-KF (Z) 	T12-KRZ Shape-KR (Z) 			

\* These tips are tinned on the soldering surface only.

Heavy duty type

T12-WB2 Shape-0.5WB 	T12-WD08 Shape-0.8WD 	T12-WD12 Shape-1.2WD 	T12-WD16 Shape-1.6WD 	T12-WD52 Shape-5.2WD 	T12-WI Shape-WI 

# IH Soldering Station

**HAKKO** FX-100 **ESD SAFE**  
SOLDERING STATION

**GOOD DESIGN**

## IH Soldering Station Digital

Tip not included



- Provides the heat to the tip effectively by an 'Induction heater'
- Unique "Power assist" feature that assists the thermal recovery performance of the soldering iron tip
- No calibration is required
- Wide variety of tips available
- Meets or exceeds IPC J-STD-001 and ANSI ESD S20.20.

### Optional Tips for FX-1001

Unit: mm

<b>T31-XX BC1</b> "01" for 450°C (A: 71.5) "02" for 400°C (A: 68.5) "03" for 350°C (A: 68.5)				
<b>T31-01BC1 Shape-1BC</b> T31-02BC1 T31-03BC1 	<b>T31-01BC28 Shape-2.8BC</b> T31-02BC28 T31-03BC28 	<b>T31-01BL Shape-BL</b> T31-02BL T31-03BL 	<b>T31-01D08 Shape-0.8D</b> T31-02D08 T31-03D08 	<b>T31-01D16 Shape-1.6D</b> T31-02D16 T31-03D16 
<b>T31-01D24 Shape-2.4D</b> T31-02D24 T31-03D24 	<b>T31-01D52 Shape-5.2D</b> T31-02D52 T31-03D52 	<b>T31-01I Shape-I</b> T31-02I T31-03I 	<b>T31-01IL Shape-IL</b> T31-02IL T31-03IL 	<b>T31-01J02 Shape-0.2RSB</b> T31-02J02 T31-03J02 
<b>T31-01JL02 Shape-0.2RLB</b> T31-02JL02 T31-03JL02 	<b>T31-01JS02 Shape-0.2RSSB</b> T31-02JS02 T31-03JS02 	<b>T31-01KU Shape-KU</b> T31-02KU T31-03KU 	<b>T31-01SBL Shape-SBL</b> T31-02SBL T31-03SBL 	<b>T31-01WD08 Shape-0.8WD</b> T31-02WD08 T31-03WD08 

### Optional Tips for FX-1002

Unit: mm

<b>T35-XX D06</b> "02" for 400°C (A: 64) "03" for 350°C (A: 64)				
<b>T35-02D06 Shape-0.6D</b> T35-03D06 	<b>T35-02D1 Shape-1D</b> T35-03D1 	<b>T35-02I Shape-I</b> T35-03I 	<b>T35-02J Shape-J</b> T35-03J 	<b>T35-02KU Shape-KU</b> T35-03KU 

## Features

### IH (induction heater) for excellent thermal efficiency. Ideal for the most challenging soldering jobs.

FX-100 features IH (induction heater) that continuously powers the soldering iron and maintains the set temperature by automatically detecting even minute drops in temperature, plus HAKKO's proprietary "Power Assist" function.



FX-100 achieves powerful thermal recovery even with fine-shaped tips.

It provides excellent thermal responsiveness that conventional IH and sensor feedback systems cannot offer.

### Boost function

To increase tip temperature by 5 to 10°C (depends on tip shape) for better working efficiency.

### Connectable with micro soldering iron

For micro soldering applications under a microscope



## Micro Soldering Iron

Tip not included



## Packing List

<b>FX-100</b>	Station, Handpiece (FX-1001), Heat resistant pad, Power cord, Sleeve (green), Sleeve (gray), Cleaning wire, Iron holder, Instruction manual
<b>FX-1002 (Conversion kit)</b>	Handpiece, Sleeve (green), Heat resistant pad, Iron holder, Instruction manual

### Interactive method by LCD display with 3 buttons

#### PROFILE

```
PROFILE 1
S:HAKKO-1
U:ID-123
S:0.6 LEAD FREE
```

Station ID, user name and solder type can be registered.

#### TIP LOAD

```
TIP LOADS
APPROX.
000025 points
<RESET> <OK>
```

The soldering count is displayed.

#### TIP TIME

```
TIP TIME
0023 hours
<RESET> <OK>
```

The cumulative running time on the iron tip is displayed.

#### TIP TYPE and NORMAL MODE/BOOST MODE

```
<01>
N
*****
```

Visible tip type (01/02/03) and normal mode (N)/boost mode (B) on display.

## Specifications

Model No.	FX-100
Power consumption	28 W (85 W)
Temperature range	T31-01 Series: 450°C, T31-02 Series: 400°C T31-03 Series: 350°C
Temperature stability	±1.1°C

### Station

Output power	50 W
Output frequency	13.56 MHz
Dimensions	127 (W) × 150 (H) × 167 (D) mm
Weight	3 kg

### Soldering Iron

Tip to ground resistance	<2 Ω
Tip to ground potential	<2 mV
Heating element	IH (Induction heating)
Cord length	1.3 m
Total length*	190 mm with T31-02D24 or T31-03D24 tip 193 mm with T31-01D24 tip
Weight*	31 g (with T31-02D24 tip)

\* Without cord

Model No.	FX-1002
Temperature range	T35-02 Series: 400°C, T35-03 Series: 350°C
Tip to ground resistance	<2 Ω
Tip to ground potential	<2 mV
Heating element	IH (Induction heating)
Cord length	1.3 m
Total length*	166 mm (with T35-02D1 tip)
Weight*	21 g (with T35-02D1 tip)

\* Without cord



# Heavy Duty Soldering Station

## HAKO FX-838 SOLDERING STATION ESD SAFE

Heavy Duty Soldering Iron Digital

Tip not included

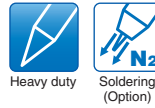

- High powered 150 W soldering iron
- Best suited for soldering of power-supply boards, heat sinks, and shield cases
- Applicable also to the soldering of multilayer boards with micro components

### Optional Tips for FX-8301

Unit: mm

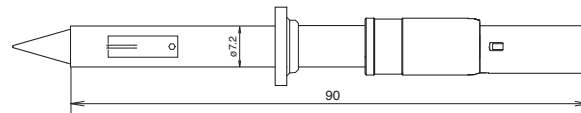

<b>T20-B2 Shape-0.5B</b> 	<b>T20-BC2 Shape-2BC T20-BCF2*</b> 	<b>T20-BC3 Shape-3BC T20-BCF3*</b> 	<b>T20-BC4 Shape-4BC T20-BCF4*</b> 	<b>T20-BCM2 Shape-2BC Bevel with indent</b> 
<b>T20-BCM3 Shape-3BC Bevel with indent</b> 	<b>T20-BL Shape-BL</b> 	<b>T20-BL2 Shape-2BL</b> 	<b>T20-BL3 Shape-3BL</b> 	<b>T20-C5 Shape-5C</b> 
<b>T20-C6 Shape-6C</b> 	<b>T20-D16 Shape-1.6D</b> 	<b>T20-D24 Shape-2.4D</b> 	<b>T20-D32 Shape-3.2D</b> 	<b>T20-D6 Shape-6D</b> 
<b>T20-J02 Shape-0.2J</b> 	<b>T20-K Shape-K</b> 	<b>T20-KU Shape-KU</b> 	<b>T20-1610</b> 	<b>T20-1611</b> 

\* These tips are tinned on the soldering surface only.

## Features

### Graph of a comparison of the performance of FX-838 and a conventional station

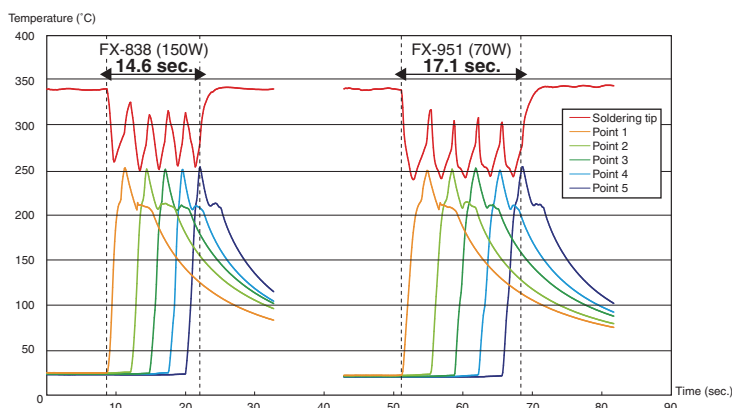

#### Test criteria

Measurement method	Thermocouples are mounted on the tip and the soldered portion on the board, and the time until the soldered portion reaches 250°C is measured for 5 points.
Board	Bakelite board
Component used	Terminal
Tip shape	Shape-1.6D
Temperature setting	340°C
Solder	Lead-free solder (Sn/Ag/Cu), diameter: 0.5 mm

### Temperature preset mode

The temperature preset mode allows you to input three frequently-used temperatures in advance and recall them with one push of a button.

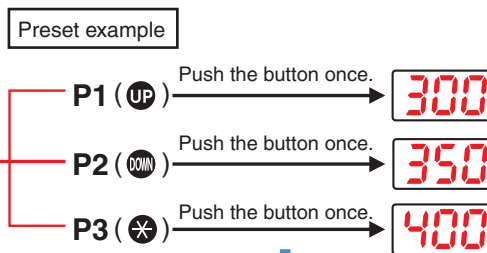

One push of a button can quickly recall each setting.

### Connectable with N<sub>2</sub> soldering iron

To improve solder wettability and spreadability

**HAKO FX-8302** ESD SAFE SOLDERING IRON

## N<sub>2</sub> Soldering Iron

Tip not included

Please see the optional tips on P.41.



For further details, see the N<sub>2</sub> system (P.38 & P.39).

## Packing List

<b>FX-838</b>	Station, Handpiece (FX-8301), Control card, Power cord, Heat resistant pad, Connecting cable, Iron holder, Instruction manual
<b>FX-8302</b>	Handpiece, Instruction manual

## Specifications

Model No.	FX-838
Power consumption	158 W
Temperature range	200 to 500°C
Temperature stability	±5°C at idle temperature

### Station

Output voltage	AC 27 V
Dimensions	110 (W) × 110 (H) × 205 (D) mm
Weight	3.2 kg

### Soldering Iron

Power consumption	150 W (27 V)
Tip to ground resistance	<2 Ω
Tip to ground potential	<2 mV
Heating element	Ceramic heater
Cord length	1.2 m
Total length*	175 mm (with 2.4D tip)
Weight*	31 g (with 2.4D tip)

\* Without cord

Model No.	FX-8302
Power consumption	150 W (27 V)
Temperature range	200 to 500°C
Tip to ground resistance	<2 Ω
Tip to ground potential	<2 mV
Heating element	Ceramic heater
Cord length	1.2 m
Total length*	195 mm (with 2.4D tip)
Weight*	41 g (with 2.4D tip and nozzle assembly D)

\* Without cord and tube

# High Performance Rework Station and Accessories

## HAKKO FM-203 SOLDERING STATION ESD SAFE

### 2-Port High Performance Rework Station

Digital

Tip not included



- 2 handpieces can be connected at the same time.

## HAKKO FM-206 REWORK SYSTEM ESD SAFE

### 3-Port High Performance Rework Station

Digital

Tip not included

Nozzle not included



- 3-port rework station that enables soldering, desoldering, and SMD rework all with a single unit
- Graphic LCD enables easy viewing and operation.

### Handpiece Combination Examples

#### FM-203



Handpiece	Channel D connector	Channel S connector
FM-2027	○	○
FM-2022 *1	○	×
FM-2023 *1	○	×
FM-2024 *2	○	○
FM-2026 *3	○	○
FM-2032	○	○

\*1 When FM-2022 or FM-2023 is connected to the channel D connector, both channel connectors can't be used at the same time.  
 \*2 When two FM-2024s are connected to the channel connectors, each FM-2024 must be connected to the desolder control box.  
 \*3 For FM-2026, each handpiece needs an N<sub>2</sub> generator (FX-780), flowmeter (FX-791), compressor, regulator, etc. For further details, see N<sub>2</sub> system (P.38 & P.39).

#### FM-206

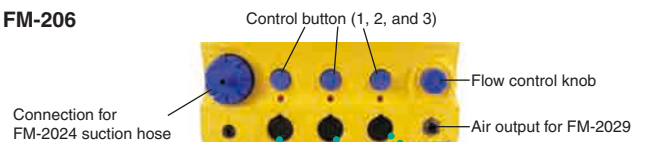

Handpiece	Receptacle 1	Receptacle 2	Receptacle 3
FM-2027	○	○	○
FM-2024	○ *1	○	○ *1
FM-2029	×	×	○
FM-2022	×	○	×
FM-2023	×	○	×
FM-2026	○	○	○
FM-2030	×	○	○
FM-2031	×	○ *2	○ *2
FM-2032	○	○	○

\*1 FM-2024 can be connected to receptacle 2 and 3. However, only one FM-2024 can be used with the station.  
 \*2 For FM-2031 and FM-2026, each handpiece needs an N<sub>2</sub> generator (FX-780), flowmeter (FX-791), compressor, regulator, etc. For further details, see N<sub>2</sub> system (P.38 & P.39).  
**NOTE:** FM-2024 and FM-2029 can't be used at the same time.

Accessories

**HAJKO FM-2027** SOLDERING IRON ESD SAFE

Soldering Iron

Tip not included



**HAJKO FM-2026** SOLDERING IRON ESD SAFE

N<sub>2</sub> Soldering Iron

Tip not included



**HAJKO FM-2029** HOT AIR HANDPIECE ESD SAFE

Hot-Air Pencil

Nozzle not included



**HAJKO FM-2030** SOLDERING IRON ESD SAFE

Heavy Duty Soldering Iron

Tip not included



**HAJKO FM-2031** SOLDERING IRON ESD SAFE

N<sub>2</sub> Heavy Duty Soldering Iron

Tip not included



**HAJKO FM-2032** SOLDERING IRON ESD SAFE

Micro Soldering Iron

Tip not included



N<sub>2</sub> Soldering is available with optional parts (P.39 & P.41).

**HAJKO MODEL FM-2022** PARALLEL REMOVER ESD SAFE

SMD Hot Tweezers

Tip not included



**HAJKO MODEL FM-2023** MINI PARALLEL REMOVER ESD SAFE

Mini SMD Hot Tweezers

Tip included



**HAJKO MODEL FM-2024** DESOLDERING TOOL ESD SAFE

Desoldering Tool

Nozzle not included





# High Performance Rework Station and Accessories

## Specifications

Model No.	FM-203
Power consumption	140 W
Temperature range	FM-2026/2027: 200 to 450°C FM-2022/2023: 200 to 400°C FM-2032: 200 to 450°C FM-2024: 350 to 450°C
Temperature stability	±5°C at idle temperature

### Station

Output voltage	AC 24 V
Dimensions	120 (W) × 120 (H) × 190 (D) mm
Weight	2.7 kg

### Soldering Iron (FM-2027)

Power consumption	70 W (24 V)
Tip to ground resistance	<2 Ω
Tip to ground potential	<2 mV
Heating element	Composite heater
Cord length	1.2 m
Total length*	188 mm (with 2.4D tip)
Weight*	30 g (with 2.4D tip)

\* Without cord

Model No.	FM-206
Power consumption	410 W (450 W, max.)
Temperature range	FM-2026/2027: 200 to 450°C FM-2022/2023: 200 to 400°C FM-2024: 350 to 450°C FM-2029: 100 to 550°C FM-2030: 200 to 500°C FM-2031: 200 to 500°C FM-2032: 200 to 450°C
Temperature stability	±5°C at idle temperature

### Station

Output voltage	AC 24 V
Vacuum generator	Vacuum pump, cylinder type
Vacuum pressure	80 kPa (600 mmHg, max.)
Suction flow	14 L/min.
Air flow	6 L/min. (max.)
Dimensions	162 (W) × 136 (H) × 245 (D) mm
Weight*	6.2 kg

### Soldering Iron (FM-2027)

Power consumption	70 W (24 V)
Tip to ground resistance	<2 Ω
Tip to ground potential	<2 mV
Heating element	Composite heater
Cord length	1.2 m
Total length*	188 mm (with 2.4D tip)
Weight*	30 g (with 2.4D tip)

### Desoldering Tool (FM-2024)

Power consumption	70 W (24 V)
Nozzle to ground resistance	<2 Ω
Nozzle to ground potential	<2 mV
Heating element	Composite heater
Cord length	1.2 m
Total length*	180 mm (with ø1 mm nozzle)
Weight**	65 g (with ø1 mm nozzle)

### Hot Air Handpiece (FM-2029)

Power consumption	140 W (24 V)
Nozzle to ground resistance	<2 Ω
Nozzle to ground potential	<2 mV
Heating element	Composite heater
Cord length	1.2 m
Total length***	232 mm (with ø4 mm nozzle)
Weight***	50 g (with ø4 mm nozzle)

\* Without cord \*\* Without cord and hose \*\*\* Without cord and tube

Model No.	FM-2022
Power consumption	140 W (24 V)
Tip to ground resistance	<2 Ω
Tip to ground potential	<2 mV
Heating element	Composite heater
Cord length	1.2 m
Total length*	148 mm (with SOP 25L tip)
Weight*	64 g (with SOP 25L tip)

\* Without cord

Model No.	FM-2023
Power consumption	140 W (24 V)
Tip to ground resistance	<2 Ω
Tip to ground potential	<2 mV
Heating element	Composite heater
Standard tip	Shape-I: 2 pcs/set (No.T9-I)
Cord length	1.2 m
Total length*	117 mm (with I tip)
Weight*	37 g (with I tip)

\* Without cord

Model No.	FM-2024
Power consumption	70 W (24 V)
Nozzle to ground resistance	<2 Ω
Nozzle to ground potential	<2 mV
Heating element	Composite heater
Cord length	1.2 m
Total length**	180 mm (with ø1 mm nozzle)
Weight**	65 g (with ø1 mm nozzle)

### Desolder Control Box

Power consumption	12 W (24 V)
Vacuum generator	Ejector type
Vacuum pressure	93 kPa (700 mmHg, max.)
Suction flow	20 L/min.
Nozzle to ground potential	<2 mV
Applied air pressure	490 kPa (5 kgf/cm <sup>2</sup> ) While in use (trigger or button is pressed)
Compressed air consumption	46 L/min.
Outer dimensions	119 (W) × 45 (H) × 172 (D) mm
Weight*	1.2 kg

\* Without cord \*\* Without cord and hose

Model No.	FM-2026
Power consumption	70 W (24 V)
Tip to ground resistance	<2 Ω
Tip to ground potential	<2 mV
Heating element	Composite heater
Cord length	1.2 m
Total length**	205 mm (with 2.4D tip)
Weight**	45 g (with 2.4D tip and nozzle assembly C)

\* Use this N<sub>2</sub> soldering iron below 400°C.

\*\* Without cord and tube

Model No.	FM-2027
Power consumption	70 W (24 V)
Tip to ground resistance	<2 Ω
Tip to ground potential	<2 mV
Heating element	Composite heater
Cord length	1.2 m
Total length*	188 mm (with 2.4D tip)
Weight*	30 g (with 2.4D tip)

\* Without cord

## Specifications

Model No.	FM-2030
Power consumption	140 W (24 V)
Tip to ground resistance	<2 Ω
Tip to ground potential	<2 mV
Heating element	Composite heater
Cord length	1.3 m
Total length*	224 mm (with 2.4D tip)
Weight*	41 g (with 2.4D tip)

\* Without cord

Model No.	FM-2032
Power consumption	48 W (24 V)
Tip to ground resistance	<2 Ω
Tip to ground potential	<2 mV
Heating element	Composite heater
Cord length	1.3 m
Total length*	170 mm (with 1D tip)
Weight*	14 g (with 1D tip)

\* Without cord

Model No.	FM-2031
Power consumption	140 W (24 V)
Tip to ground resistance	<2 Ω
Tip to ground potential	<2 mV
Heating element	Composite heater
Cord length	1.2 m
Total length*	231 mm (with 2.4D tip)
Weight*	47 g (with 2.4D tip and nozzle assembly E)

\* Without cord and tube

## Packing List

<b>FM-203</b>	Station, Handpiece (FM-2027), Sleeve assembly, Connecting cable, Power cord, Control card, Iron holder, Tip tray, Heat resistant pad, Instruction manual
<b>FM-206</b>	Station, Power cord, Tip tray, Desoldering tool (FM-2024), Handle (for gun configuration for FM-2024), Iron holder (for FM-2024), Ceramic paper filter (10 pcs; for FM-2024), Nozzle remover (for FM-2024), Cleaning drill for heating element (for FM-2024), Connecting cable (for FM-2024), Handpiece (FM-2027), Iron holder (for FM-2027), Heat resistant pad (for FM-2027), Connecting cable (for FM-2027), Hot air handpiece (FM-2029), Iron holder (for FM-2029), Heat resistant pad (for FM-2029), Connecting cable (for FM-2029), Instruction manual
<b>FM-2022 (Conversion kit)</b>	Parallel remover, Heat resistant pad, Iron holder, Connecting cable, Instruction manual
<b>FM-2023 (Conversion kit)</b>	Mini parallel remover, Soldering tip (T9-I), Heat resistant pad, Iron holder, Component bed, Connecting cable, Instruction manual

<b>FM-2024 (Conversion kit, with DCB)</b>	Desoldering tool, Handle (for gun configuration), Desoldering control box, Filter pipe assembly, Iron holder, Cleaning drill for heating element, Nozzle remover, Ceramic paper filter (10 pcs), Connecting cable, Instruction manual
<b>FM-2026 (Conversion kit)</b>	Handpiece, Sleeve cover, Sleeve assembly (yellow), Heat resistant pad, Iron holder, Connecting cable, Instruction manual
<b>FM-2027 (Conversion kit)</b>	Handpiece, Sleeve assembly (yellow), Heat resistant pad, Iron holder, Connecting cable
<b>FM-2029 (Conversion kit)</b>	Handpiece (hot air), Handpiece holder, Heat resistant pad, Connecting cable, Instruction manual
<b>FM-2030 (Conversion kit)</b>	Handpiece (soldering), Heat resistant pad, Iron holder, Connecting cable, Instruction manual
<b>FM-2031 (Conversion kit)</b>	Handpiece (soldering), Heat resistance pad, Iron holder, Connecting cable, Instruction manual
<b>FM-2032 (Conversion kit)</b>	Handpiece, Heat resistant pad, Iron holder, Connecting cable, Instruction manual

## FM-2029 Features

Securely and easily remove 10 × 10 (mm) chips.



## FM-2032 Size

Unit: mm



## FM-2030 Features

Graph of a comparison of the performance of FM-2027 (70 W) and FM-2030 (140 W)

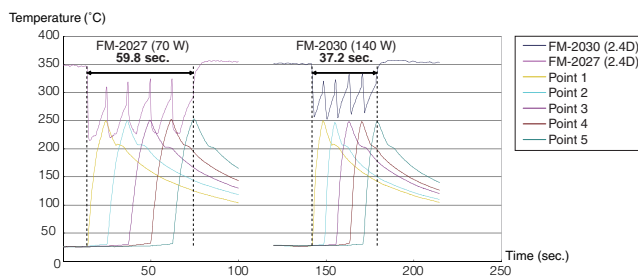

## Test criteria







Test method	Solder at 5 points and measure the time until the temperature of the workpiece reaches 250°C.
Board	Bakelite board
Component used	Screw
Tip shape	Shape-2.4D
Temperature setting	350°C
Solder	Lead-free solder (Sn/Ag/Cu), diameter: 1 mm

# High Performance Rework Station and Accessories

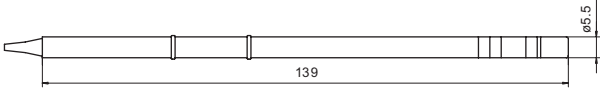
## Optional Tips for FM-207

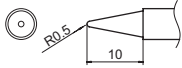
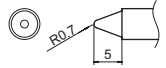
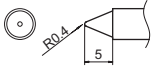
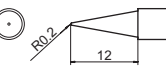
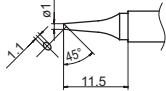
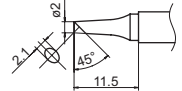
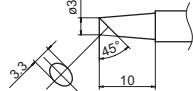
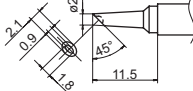
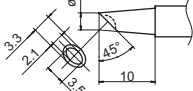
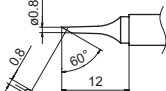
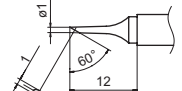
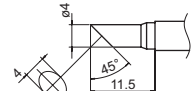
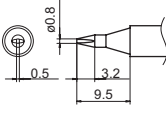
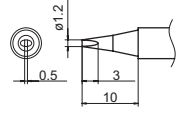
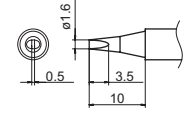
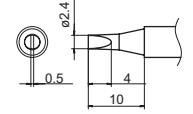
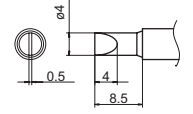
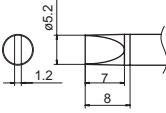
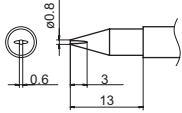
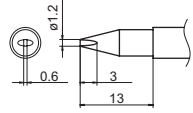
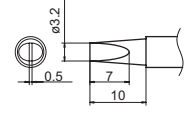
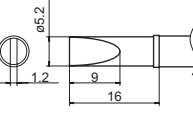
Unit: mm

### Standard type

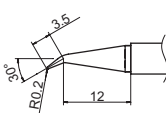
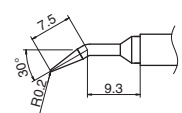
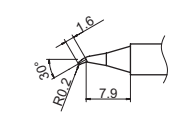
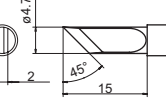
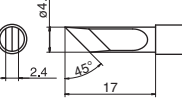
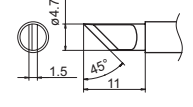
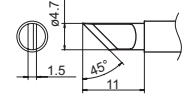
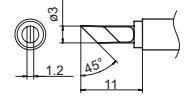
					
<b>B</b>	<b>T12-B Shape-B</b> 	<b>T12-B2 Shape-0.5B</b> 	<b>T12-B3 Shape-0.7B</b> 	<b>T12-B4 Shape-0.4B</b> 	<b>T12-BL Shape-BL</b> 
<b>BC</b>	<b>T12-BC1 Shape-1BC T12-BCF1*</b> 	<b>T12-BC2 Shape-2BC T12-BCF2*</b> 	<b>T12-BC3 Shape-3BC T12-BCF3*</b> 	<b>T12-BCM2 Shape-2BC Bevel with indent</b> 	<b>T12-BCM3 Shape-3BC Bevel with indent</b> 
<b>C</b>	<b>T12-C08 Shape-0.8C</b> 	<b>T12-C1 Shape-1C</b> 	<b>T12-C4 Shape-4C T12-CF4*</b> 		
<b>D</b>	<b>T12-D08 Shape-0.8D</b> 	<b>T12-D12 Shape-1.2D</b> 	<b>T12-D16 Shape-1.6D</b> 	<b>T12-D24 Shape-2.4D</b> 	<b>T12-D4 Shape-4D</b> 
	<b>T12-D52 Shape-5.2D</b> 	<b>T12-DL08 Shape-0.8DL</b> 	<b>T12-DL12 Shape-1.2DL</b> 	<b>T12-DL32 Shape-3.2DL</b> 	<b>T12-DL52 Shape-5.2DL</b> 
<b>I</b>	<b>T12-I Shape-I</b> 	<b>T12-IL Shape-IL</b> 	<b>T12-ILS Shape-ILS</b> 		
<b>J</b>	<b>T12-J02 Shape-0.2J</b> 	<b>T12-JL02 Shape-0.2JL</b> 	<b>T12-JS02 Shape-0.2JS</b> 		
<b>K</b>	<b>T12-K Shape-K</b> 	<b>T12-KF Shape-KF</b> 	<b>T12-KL Shape-KL</b> 	<b>T12-KR Shape-KR</b> 	<b>T12-KU Shape-KU</b> 

\* These tips are tinned on the soldering surface only.

### Concave type

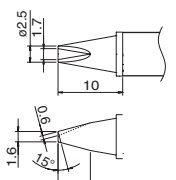
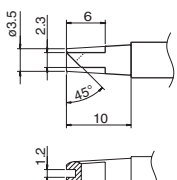
<b>T12-1610</b> 	<b>T12-1612</b> 
--	--

SMD type

Quad	T12-1201 Quad 13.6 x 8.5 	T12-1202 Quad 10.3 x 10.3 	T12-1203 Quad 12.8 x 12.8 	T12-1204 Quad 17.9 x 17.9 	T12-1205 Quad 23.4 x 17.3 
	T12-1206 Quad 22.5 x 16.5 	T12-1207 Quad 15.5 x 15.5 	T12-1208 Quad 15.8 x 15.8 	T12-1209 Quad 8.4 x 8.4 	
Tunnel	T12-1001 Tunnel 5.1 x 4.6 	T12-1002 Tunnel 5.1 x 10.4 	T12-1003 Tunnel 9.5 x 18.3 	T12-1004 Tunnel 9.5 x 15.8 	T12-1005 Tunnel 9.5 x 13.2 
	T12-1006 Tunnel 6.9 x 11.4 	T12-1007 Tunnel 7.9 x 18.8 	T12-1008 Tunnel 19.5 x 10.2 	T12-1009 Tunnel 13.4 x 20.5 	T12-1010 Tunnel 19.5 x 12 
Spatula	T12-1401 Spatula 10.4 	T12-1402 Spatula 15.7 	T12-1403 Spatula 21.2 	T12-1404 Spatula 25 	T12-1405 Spatula 32 
	T12-1406 Spatula 40 				

Long life type

T12-BZ Shape-B (Z) 	T12-B2Z Shape-0.5B (Z) 	T12-BC1Z Shape-1BC (Z) T12-BCF1Z* 	T12-BC2Z Shape-2BC (Z) T12-BCF2Z* 	T12-BC3Z Shape-3BC (Z) T12-BCF3Z* 
T12-C4Z Shape-4C (Z) T12-CF4Z* 	T12-D12Z Shape-1.2D (Z) 	T12-D16Z Shape-1.6D (Z) 	T12-D24Z Shape-2.4D (Z) 	T12-D4Z Shape-4D (Z) 
T12-KFZ Shape-KF (Z) 	T12-KRZ Shape-KR (Z) 			

\* These tips are tinned on the soldering surface only.

Heavy duty type

T12-WB2 Shape-0.5WB 	T12-WD08 Shape-0.8WD 	T12-WD12 Shape-1.2WD 	T12-WD16 Shape-1.6WD 	T12-WD52 Shape-5.2WD 	T12-WI Shape-WI 

# High Performance Rework Station and Accessories

## Optional Tips for FM-2032

Unit: mm

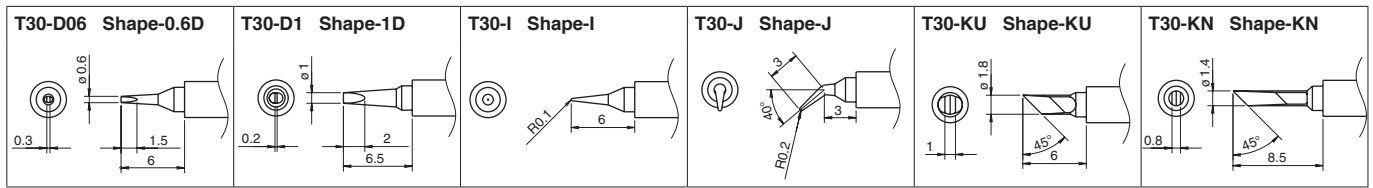

## Optional Tips for FM-2022

Unit: mm

### CHIP

\*1 set: 2 pcs

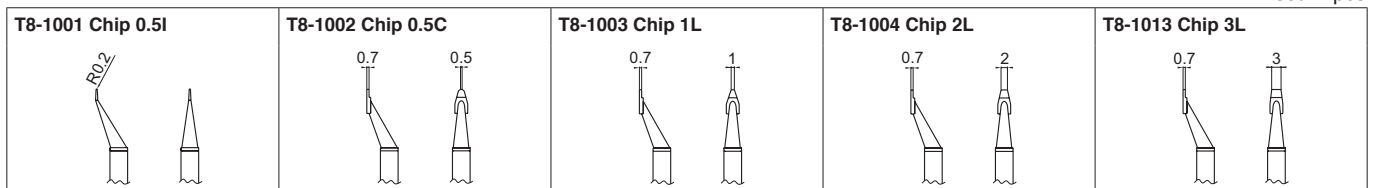

### SOP

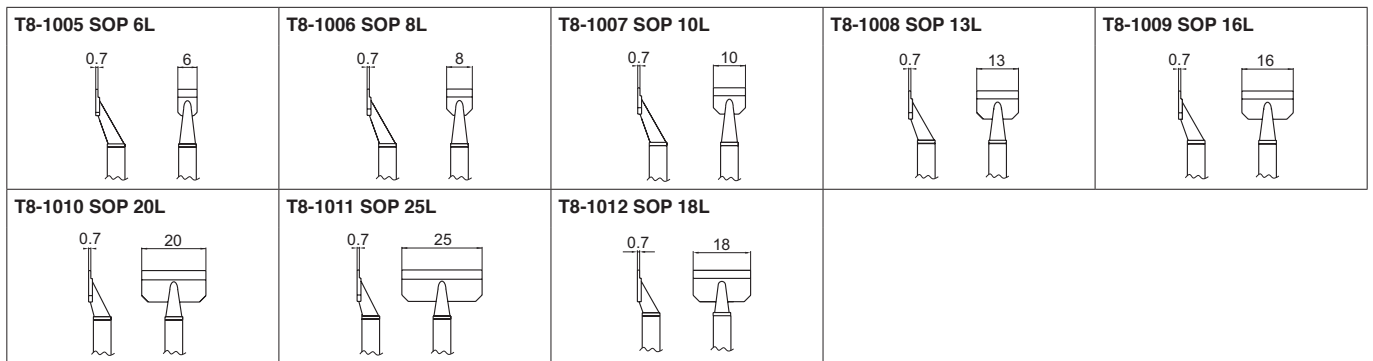

## Replacement Tips for FM-2023

Unit: mm

### CHIP

\*1 set: 2 pcs

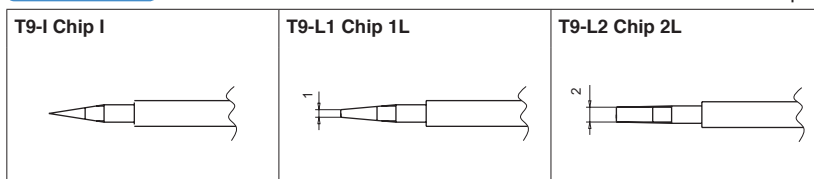

## Optional Tips for FM-2030

Unit: mm

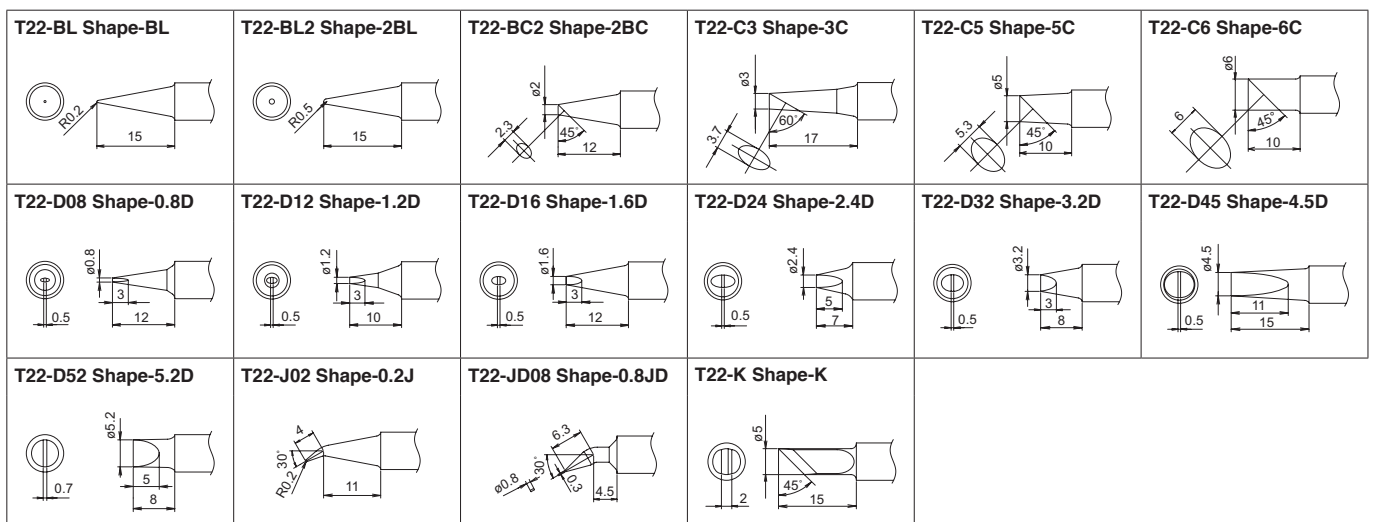



**Optional Nozzles for FM-2024**

Unit: mm

<p><b>N1-06 Nozzle <math>\phi 0.6</math></b></p>	<p><b>N1-08 Nozzle <math>\phi 0.8</math></b></p>	<p><b>N1-10 Nozzle <math>\phi 1</math></b></p>	<p><b>N1-13 Nozzle <math>\phi 1.3</math></b></p>	<p><b>N1-16 Nozzle <math>\phi 1.6</math></b></p>
<p><b>N1-20 Nozzle <math>\phi 2</math></b></p>	<p><b>N1-23 Nozzle <math>\phi 2.3</math></b></p>	<p><b>N1-L10 Nozzle <math>\phi 1</math> long</b></p>		

**Optional Nozzles for FM-2029**

Unit: mm

		$\phi A$	$\phi B$
<b>N4-01 Nozzle <math>\phi 2</math></b>		2	2.5
<b>N4-02 Nozzle <math>\phi 4</math></b>		4	5
<b>N4-03 Nozzle <math>\phi 6</math></b>		6	7
<b>N4-04 Nozzle <math>\phi 8</math></b>		8	9

**Optional Tips for the FM-2026**

Please see the optional tips on P.40.

**Optional Tips for the FM-2031**

Please see the optional tips on P.40.



## HAKKO FX-780 / FX-781

### N<sub>2</sub> Generator



- Highest concentration of nitrogen gas: 99.9%
- Compact design reduces footprint.
- Large-capacity type accepts 2 soldering irons (FX-781).

## HAKKO FX-791

### N<sub>2</sub> Flowmeter



- Flowmeter for N<sub>2</sub> soldering iron with flow control valve and regulator

- The preheating effect is achieved by passing Nitrogen gas along the heating element in the hand piece.
- Improvement of wettability and spreadability
- Preventing oxidation

### Connection Method

#### For two soldering irons

Large-capacity type : FX-781

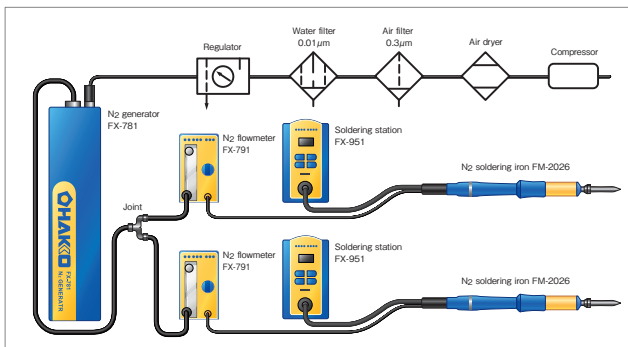

\* It is capable to supply high concentration Nitrogen of 97% at the output rate approx. 1L /min. (at air supply pressure of 0.5MPa)

#### For one soldering iron

Small-capacity type : FX-780  
Large-capacity type : FX-781

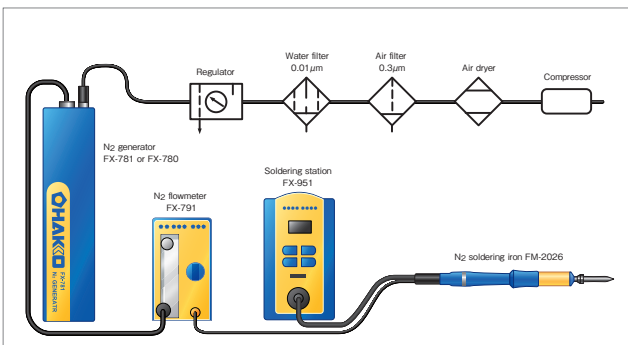

\* It is capable to supply high concentration Nitrogen of 99.9% at the output rate approx. 1L /min. (at air supply pressure of 0.7MPa)

### Specifications

Model No.	FX-780	FX-781
Air supply pressure	0.3 to 0.7 MPa	
Concentration of generated N <sub>2</sub>	99.9% (max.)	
Amount of generated N <sub>2</sub>	1.5 L/min. (When compressed air of 0.5 MPa is supplied at 25°C, the concentration of the generated nitrogen is 98%.)	2.4 L/min. (When compressed air of 0.5 MPa is supplied at 25°C, the concentration of the generated nitrogen is 98%.)
Dimensions*	73 (W) × 282 (H) × 71 (L) mm	73 (W) × 407 (H) × 71 (L) mm
Weight**	1.5 kg	2 kg

\* Without sockets and valve  
\*\* Without racks

Model No.	FX-791
Pressure of discharged gas	0.2 MPa (2 kgf/cm <sup>2</sup> )
Gas flow	0.25 to 2.5 L/min.
Dimensions	70 (W) × 121 (H) × 134 (D) mm
Weight	600 g

### Packing List

FX-780	Unit, Rack for unit (2 pcs), Instruction manual
FX-791	Unit, Instruction manual
FX-781	Unit, Racks for unit (4 pcs), Instruction manual

## Applicable Soldering Station

### N<sub>2</sub> Soldering Iron

<p>FX-8802 <b>65 W</b></p>	<p>FM-2032 <b>New</b> <b>48 W</b></p>	<p>FM-2026 <b>70 W</b></p>	<p>FM-2031 <b>140 W</b></p>	<p>FX-8302 <b>150 W</b></p>	<p>FX-8003 <b>260 W</b></p>
<p>FX-888D FX-889 * Use FX-8802 below 450°C.</p>	<p>FX-951 FM-206 FM-203</p>	<p>FX-951 FM-206 FM-203 FM-204 FX-950 * Use FM-2026 below 400°C.</p>	<p>FM-206</p>	<p>FX-838</p>	<p>FX-801</p>

## Effects of N<sub>2</sub> system

Heated N<sub>2</sub> gas discharged from the tip end produces three effects. As a result, solderability increases, which allows you to enjoy the following advantages.

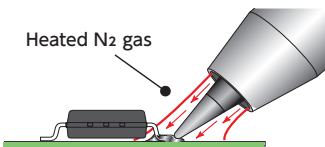

- Compatible with no-clean soldering (low-activity flux)
- Solves the insufficient heat supply problems which may occur during soldering of multilayer boards
- Reduces tip oxidation
- Reduces soldering time
- Relieves loads applied to heat-sensitive parts

### Improving wettability

Heated N<sub>2</sub> gas preheats P.W.B.s and shuts out oxygen. As a result, it prevents the oxidation of solder and flux and improves wettability.

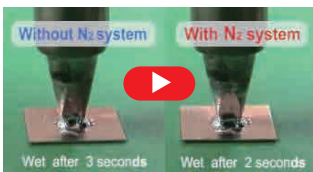

### Preventing oxidation

Heated N<sub>2</sub> gas reduces the oxidization of tips (iron plating). As a result, the wettability of tips is improved.



#### Test criteria

- After applying power for 3 hours with the temperature set at 400°C, feed solder and perform cleaning, and then compare the conditions.

### Preheating effect

Heated N<sub>2</sub> gas preheats the workpiece. As a result, even if the temperature setting is low, soldering can be finished in the same time as before.

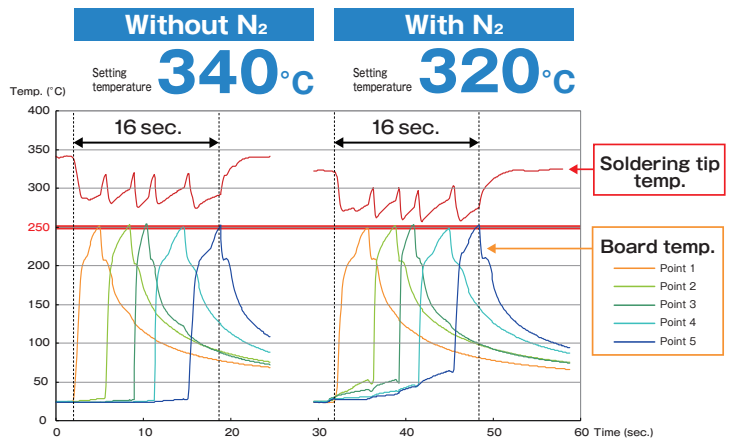

#### Test criteria

- Board: Paper phenol copper board
- Component: Connector
- Solder: Lead-free solder (Sn-3Ag-0.5Cu)  $\phi$ 0.5mm
- Tip shape: T12-D24 and T13-D24
- Measurement method: Measure the time until the workpiece reached to 250°C at 5-points

The three effects result in improved workability, quality stability and reduced running cost.

## Replacement Tips and Nozzle Assemblies for FX-8802

Tip and nozzle assembly are supplied separately. Please purchase a compatible nozzle assembly for your tip referring the chart below.

Unit: mm

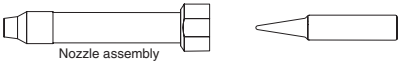
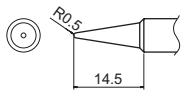
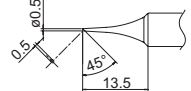
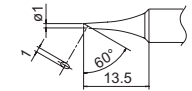
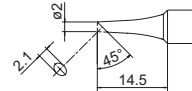
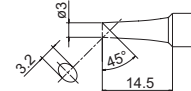
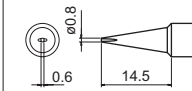
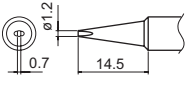
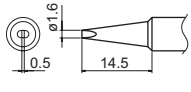
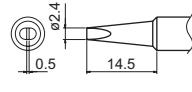
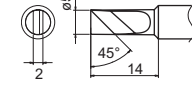
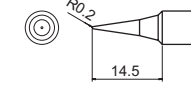
 <p>Nozzle assembly</p>					
<b>T18-B Shape-B</b> 	<b>T18-C05 Shape-0.5C</b> 	<b>T18-C1 Shape-1C</b> <b>T18-CF1*</b> 	<b>T18-C2 Shape-2C</b> <b>T18-CF2*</b> 	<b>T18-C3 Shape-3C</b> <b>T18-CF3*</b> 	<b>T18-D08 Shape-0.8D</b> 
B3662 Nozzle assembly A	B3664 Nozzle assembly C	B3664 Nozzle assembly C	B3662 Nozzle assembly A	B3663 Nozzle assembly B	B3662 Nozzle assembly A
<b>T18-D12 Shape-1.2D</b> 	<b>T18-D16 Shape-1.6D</b> 	<b>T18-D24 Shape-2.4D</b> 	<b>T18-K Shape-K</b> 	<b>T18-I Shape-I</b> 	* These tips are tinned on the soldering surface only.
B3662 Nozzle assembly A	B3663 Nozzle assembly B	B3663 Nozzle assembly B	B3665 Nozzle assembly D	B3664 Nozzle assembly C	

## Optional Tips and Nozzle Assemblies for FM-2026

Tip and nozzle assembly are supplied separately. Please purchase a compatible nozzle assembly for your tip referring the chart below.

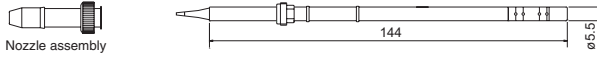
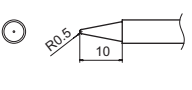
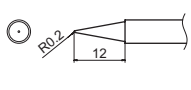
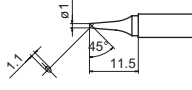
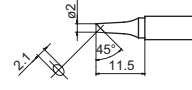
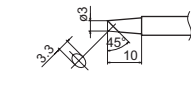
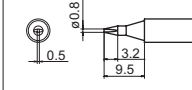
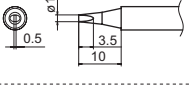
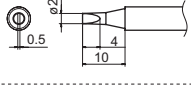
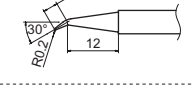
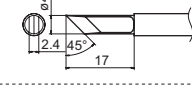
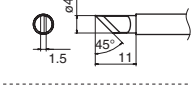
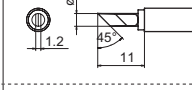
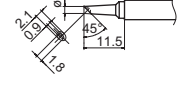
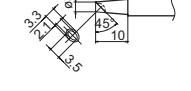

Unit: mm

 <p>Nozzle assembly</p>					
<b>T13-B2 Shape-0.5B</b> 	<b>T13-BL Shape-BL</b> 	<b>T13-BC1 Shape-1BC</b> <b>T13-BCF1*</b> 	<b>T13-BC2 Shape-2BC</b> <b>T13-BCF2*</b> 	<b>T13-BC3 Shape-3BC</b> <b>T13-BCF3*</b> 	<b>T13-D08 Shape-0.8D</b> 
B2708 Nozzle assembly C	B2898 Nozzle assembly E	B2899 Nozzle assembly F	B2706 Nozzle assembly A	B2900 Nozzle assembly G	B2709 Nozzle assembly D
<b>T13-D16 Shape-1.6D</b> 	<b>T13-D24 Shape-2.4D</b> 	<b>T13-J02 Shape-0.2J</b> 	<b>T13-KF Shape-KF</b> 	<b>T13-KR Shape-KR</b> 	<b>T13-KU Shape-KU</b> 
B2708 Nozzle assembly C	B2708 Nozzle assembly C	B2707 Nozzle assembly B	B2923 Nozzle assembly J	B2902 Nozzle assembly I	B2901 Nozzle assembly H
<b>T13-BCM2 Shape-2BC</b> <b>Bevel with indent</b> 	<b>T13-BCM3 Shape-3BC</b> <b>Bevel with indent</b> 	* These tips are tinned on the soldering surface only.			
B2706 Nozzle assembly A	B2900 Nozzle assembly G				

## Optional Tips and Nozzle Assemblies for FM-2031

Tip and nozzle assembly are supplied separately. Please purchase a compatible nozzle assembly for your tip referring the chart below.

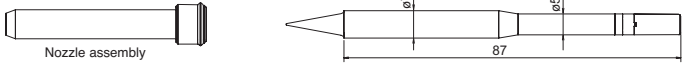
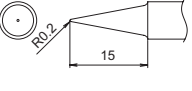
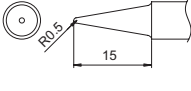
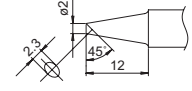
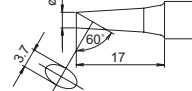
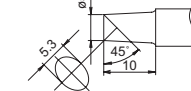
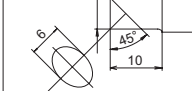
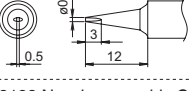
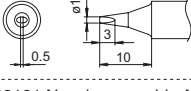
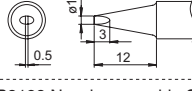
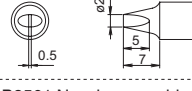
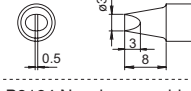
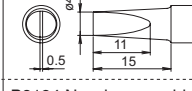
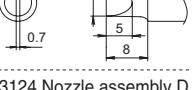
Unit: mm

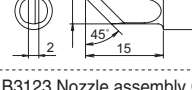
 <p>Nozzle assembly</p>					
<b>T22-BL Shape-BL</b> 	<b>T22-BL2 Shape-2BL</b> 	<b>T22-BC2 Shape-2BC</b> 	<b>T22-C3 Shape-3C</b> 	<b>T22-C5 Shape-5C</b> 	<b>T22-C6 Shape-6C</b> 
B3121 Nozzle assembly A	B3121 Nozzle assembly A	B3121 Nozzle assembly A	B3121 Nozzle assembly A	B3124 Nozzle assembly D	B3124 Nozzle assembly D
<b>T22-D08 Shape-0.8D</b> 	<b>T22-D12 Shape-1.2D</b> 	<b>T22-D16 Shape-1.6D</b> 	<b>T22-D24 Shape-2.4D</b> 	<b>T22-D32 Shape-3.2D</b> 	<b>T22-D45 Shape-4.5D</b> 
B3123 Nozzle assembly C	B3121 Nozzle assembly A	B3123 Nozzle assembly C	B3561 Nozzle assembly E	B3124 Nozzle assembly D	B3124 Nozzle assembly D
<b>T22-D52 Shape-5.2D</b> 	<b>T22-J02 Shape-0.2J</b> 	<b>T22-JD08 Shape-0.8JD</b> 	<b>T22-K Shape-K</b> 		
B3124 Nozzle assembly D	B3121 Nozzle assembly A	B3561 Nozzle assembly E	B3123 Nozzle assembly C		

### Optional Tips and Nozzle Assemblies for FM-2032

Tip and nozzle assembly are supplied separately. Please purchase a compatible nozzle assembly for your tip referring the chart below.

Unit: mm

<p>C5038 Nozzle assembly A C5039 Nozzle assembly B C5040 Nozzle assembly C C5041 Nozzle assembly D*</p>					
<p><b>T30-D1 Shape-1D</b></p>	<p><b>T30-D06 Shape-0.6D</b></p>	<p><b>T30-I Shape-I</b></p>	<p><b>T30-J Shape-J</b></p>	<p><b>T30-KU Shape-KU</b></p>	<p><b>T30-KN Shape-KN</b></p>
<p>C5038 Nozzle assembly A C5041 Nozzle assembly D*</p>	<p>C5038 Nozzle assembly A C5041 Nozzle assembly D*</p>	<p>C5038 Nozzle assembly A C5041 Nozzle assembly D*</p>	<p>C5040 Nozzle assembly C C5041 Nozzle assembly D*</p>	<p>C5038 Nozzle assembly A C5041 Nozzle assembly D*</p>	<p>C5039 Nozzle assembly B C5041 Nozzle assembly D*</p>

\* Shorter nozzle design provides better visibility.  
For further information, visit our website.

### Optional Tips and Nozzle Assemblies for FX-8302

Tip and nozzle assembly are supplied separately. Please purchase a compatible nozzle assembly for your tip referring the chart below.

Unit: mm

<p><b>T20-B2 Shape-0.5B</b></p>	<p><b>T20-BL Shape-BL</b></p>	<p><b>T20-BL2 Shape-2BL</b></p>	<p><b>T20-J02 Shape-0.2J (0.2RSB)</b></p>	<p><b>T20-KU Shape-KU</b></p>	<p><b>T20-BL3 Shape-3BL</b></p>
B3121 Nozzle assembly A	B3121 Nozzle assembly A	B3121 Nozzle assembly A	B3122 Nozzle assembly B	B3122 Nozzle assembly B	B3123 Nozzle assembly C
<p><b>T20-D16 Shape-1.6D</b></p>	<p><b>T20-K Shape-K</b></p>	<p><b>T20-BC2 Shape-2BC T20-BCF2*</b></p>	<p><b>T20-BC3 Shape-3BC T20-BCF3*</b></p>	<p><b>T20-BC4 Shape-4BC T20-BCF4*</b></p>	<p><b>T20-C5 Shape-5C</b></p>
B3123 Nozzle assembly C	B3123 Nozzle assembly C	B3124 Nozzle assembly D	B3124 Nozzle assembly D	B3124 Nozzle assembly D	B3124 Nozzle assembly D
<p><b>T20-C6 Shape-6C</b></p>	<p><b>T20-D24 Shape-2.4D</b></p>	<p><b>T20-D32 Shape-3.2D</b></p>	<p><b>T20-BCM2 Shape-2BC Bevel with indent</b></p>	<p><b>T20-BCM3 Shape-3BC Bevel with indent</b></p>	<p><b>T20-D6 Shape-6D</b></p>
B3124 Nozzle assembly D	B3124 Nozzle assembly D	B3124 Nozzle assembly D	B3124 Nozzle assembly D	B3124 Nozzle assembly D	B3561 Nozzle assembly E
<p><b>T20-1610</b></p>		<p><b>T20-1611</b></p>			
B3124 Nozzle assembly D		B3124 Nozzle assembly D			

\* These tips are tinned on the soldering surface only.

### Optional Tips and Nozzle Assemblies for FX-8003

Tip and nozzle assembly are supplied separately. Please purchase a compatible nozzle assembly for your tip referring the chart below.

Unit: mm

<p><b>T33-BC2 Shape-2BC</b></p>	<p><b>T33-BC3 Shape-3BC</b></p>	<p><b>T33-BC4 Shape-4BC</b></p>	<p><b>T33-BC5 Shape-5BC</b></p>	<p><b>T33-BC6 Shape-6BC</b></p>	<p><b>T33-D24 Shape-2.4D</b></p>
B5070 Nozzle assembly B	B5070 Nozzle assembly B	B5069 Nozzle assembly A	B5069 Nozzle assembly A	B5069 Nozzle assembly A	B5070 Nozzle assembly B
<p><b>T33-D32 Shape-3.2D</b></p>	<p><b>T33-D5 Shape-5D</b></p>	<p><b>T33-D6 Shape-6D</b></p>	<p><b>T33-1610</b></p>	<p><b>T33-1611</b></p>	
B5069 Nozzle assembly A	B5069 Nozzle assembly A	B5069 Nozzle assembly A	B5070 Nozzle assembly B	B5070 Nozzle assembly B	



# Ceramic Heater Soldering Iron

## HAKKO FX-600

SOLDERING IRON

### Temperature Adjustable Soldering Iron

Tip included



- Adjustable temperature range: 200 to 500°C

## HAKKO FX-601

STAINED GLASS

### Heavy Duty Temperature Adjustable Soldering Iron

Tip included



- Maximum temperature: 540°C

## Features

### Superior heat conductivity

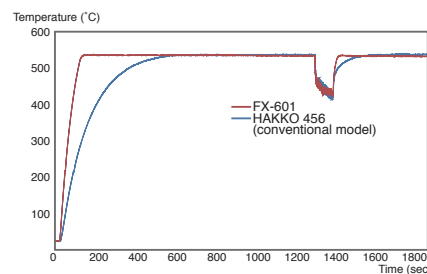
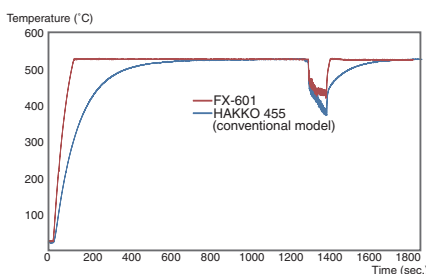
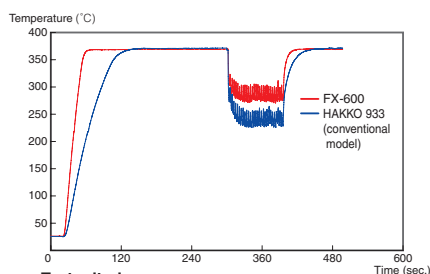

#### Test criteria

- Temperature of soldering iron with a diameter 1.6 x 5 mm piece of solder applied once every 3 seconds to paper phenol copper board.
- Lead-free solder is used.

### Detach the control knob and lock the temperature setting.



### Turn the CAL knob to attain a more accurate temperature.

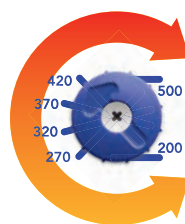

\* Accurate temperature control can be performed even outside the scale.

## Specifications

Model No.	FX-600	FX-601
Power consumption	50 W (100 V), 59 W (110 V), 74 W (120 V), 43 W (220 V), 47 W (230 V), 51 W (240 V)	47 W (100 V), 56 W (110 V), 67 W (120 V), 42 W (220 V), 46 W (230 V), 50 W (240 V)
Temperature range	200 to 500°C	240 to 540°C
Temperature stability	±1°C at idle temperature	±1°C at idle temperature
Tip to ground resistance	<2 Ω	<2 Ω
Tip to ground potential	<2 mV	<2 mV
Heating element	Ceramic heater	Ceramic heater
Standard tip	Shape-B (No. T18-B)	Shape-2B (No. T19-B2)
Total length*	233 mm (with B tip)	237 mm (with 2B tip)
Weight*	61 g (with B tip)	68 g (with 2B tip)

\* Without cord

### Packing List

<b>FX-600</b>	Unit, Lock key, Instruction manual
<b>FX-601</b>	Unit, Lock key, Instruction manual



FX-600 with 605M

### Option

Part No.	Name	Specifications
FH300-81	Iron holder	With cleaning sponge
633-01	Iron holder	With 599B
633-02	Iron holder	With cleaning sponge
605M	Iron cover	-
B3720	Tip enclosure	With nut, required when converting from FX-600 to FX-601
B3730	Nut and tip enclosure	Required when converting from FX-601 to FX-600

\* For information on the iron holders, see P.60.

### Replacement Tips for FX-600

Unit: mm

<b>T18-B Shape-B</b> 	<b>T18-BL Shape-BL</b> 	<b>T18-C05 Shape-0.5C</b> 	<b>T18-C08 Shape-0.8C</b> 	<b>T18-C1 Shape-1C</b> <b>T18-CF1*</b> 
<b>T18-C2 Shape-2C</b> <b>T18-CF2*</b> 	<b>T18-C3 Shape-3C</b> <b>T18-CF3*</b> 	<b>T18-C4 Shape-4C</b> <b>T18-CF4*</b> 	<b>T18-C5 Shape-5C</b> 	<b>T18-CF15* Shape-1.5C</b> 
<b>T18-CSF25* Shape-2.5CS</b> 	<b>T18-D08 Shape-0.8D</b> 	<b>T18-D12 Shape-1.2D</b> 	<b>T18-D16 Shape-1.6D</b> 	<b>T18-D24 Shape-2.4D</b> 
<b>T18-D32 Shape-3.2D</b> 	<b>T18-DL12 Shape-1.2DL</b> 	<b>T18-DL2 Shape-2DL</b> 	<b>T18-DL32 Shape-3.2DL</b> 	<b>T18-I Shape-I</b> 
<b>T18-BR02 Shape-0.2BR</b> 	<b>T18-K Shape-K</b> 	<b>T18-S3 Shape-S3</b> 	<b>T18-S4 Shape-S4</b> 	<b>T18-S6 Shape-S6</b> 
<b>T18-S9 Shape-S9</b> 	<b>T18-SB Shape-SB</b> 	* These tips are tinned on the soldering surface only.		

### Replacement Tips for FX-601

Unit: mm

<b>T19-B Shape-B</b> 	<b>T19-B2 Shape-2B</b> 	<b>T19-C3 Shape-3C</b> 	<b>T19-C4 Shape-4C</b> 	<b>T19-C65 Shape-6.5C</b> 
<b>T19-D24 Shape-2.4D</b> 	<b>T19-D32 Shape-3.2D</b> 	<b>T19-D5 Shape-5D</b> 	<b>T19-D65 Shape-6.5D</b> 	<b>T19-I Shape-I</b> 

# Ceramic Heater Soldering Iron

## HAKKO DASH

SOLDERING IRON

### Ceramic Heater Soldering Iron

Tip included



- An entry model of ceramic heater soldering iron
- Ideal for electronic circuit assembly



#### Packing List

FX-650	Unit
--------	------

#### Features

Slim handle improves your work efficiency!

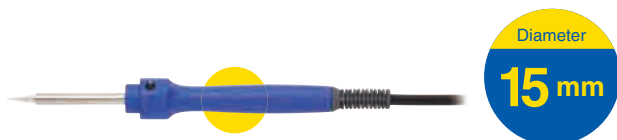

Simple and easy tip replacement



Quick change just loosening a screw

#### Specifications

Model No.	FX-650
Power consumption	15 to 16 W
Heating element	Ceramic heater
Standard tip	Shape-B (No.T34-B)
Total length*	224 mm
Weight*	60 g (with B tip)

\* Without cord

#### Option

Part No.	Name	Specifications
FH300-81	Iron holder	With cleaning sponge
633-01	Iron holder	With 599B
633-02	Iron holder	With cleaning sponge
605M	Iron cover	-

\* For information on the iron holders, see P.60.



No.605M (with FX-650)

#### Replacement Tips for DASH

Unit: mm

<b>T34-B Shape-B</b> 	<b>T34-C08 Shape-0.8C</b> 	<b>T34-C2 Shape-2C</b> 	<b>T34-C3 Shape-3C</b> 	<b>T34-C4 Shape-4C</b> 
<b>T34-D32 Shape-3.2D</b> 	<b>T34-I Shape-I</b> 			

# HAKKOPRESTO

SOLDERING IRON

## W-Switchable Ceramic Heater Soldering Iron

Tip included



- The boost switch can immediately raise the power from 20 W in normal operation mode to 130 W, which enables the soldering iron to be heated up at a high speed.
- PRESTO can be used for a wide range of applications.
- A safety cap is available for 984 and 985.

When capped



### Packing List

980, 981	Unit
984, 985	Unit, Safety cap

### Specifications

Model No.	980	981	984	985
Power consumption	20/130 W (while the switch is pushed)			
Heating element	Ceramic heater			
Standard tip	Shape-B (No. 980-T-B)			
Total length*	205 mm	160 mm	205 mm	160 mm
Weight*	48 g	92 g	56 g	100 g

\* Without cord and cap

### Option

Part No.	Name	Specifications
FH300-81	Iron holder	With cleaning sponge
633-01	Iron holder	With 599B
633-02	Iron holder	With cleaning sponge

\* For information on the iron holders, see P.60.

### Replacement Tips for PRESTO

Unit: mm

980-T-B Shape-B	980-T-BC Shape-BC	980-T-BI Shape-BI	980-T-D Shape-D

# Battery-Powered Soldering Iron

## HAJKO FX-901 CORDLESS IRON

### Battery-Powered Soldering Iron

Tip included



- Easy-to-carry soldering iron powered by AA alkaline batteries
- Cordless design makes this iron very handy and usable virtually anywhere.

#### Easy Replacement

##### Easy tip replacement

Turn the nipple  
90° clockwise.



##### Easy battery replacement



#### Packing List

FX-901	Unit, Cap
--------	-----------

\* Batteries not included

#### Specifications

Model No.	FX-901
Power supply	AA x 4 pcs
Power consumption	Alkaline batteries: 6 W (6 V) Nickel hydrogen batteries (2150 mAh): 5 W (4.8 V)
Standard tip	Shape-B (No.T11-B)
Battery life*	Alkaline batteries: 60 minutes Nickel hydrogen batteries (2150 mAh): 120 minutes
Total length**	212 mm
Weight***	76 g

Measurement conditions

- When using new batteries, performance will vary depending on the batteries.
- The operating time was measured from the point that the soldering iron was turned on to the point at which the temperature dropped below 300°C, which is the minimum temperature at which soldering can be performed.

\* When using batteries other than those specified above, the performance and the operating time will vary.

\*\* Without cap

\*\*\* Without battery

#### Replacement Tips for FX-901

Unit: mm

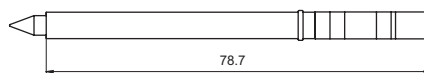

T11-B Shape-B

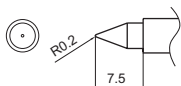

T11-D4 Shape-4D

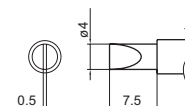



**HAKKO RED**  
SOLDERING IRON

## Nichrome Heater Soldering Iron

Tip included



- Ideal for use in a variety of soldering works



### Specifications

Model No.	500	501	502	503
Power consumption	20 W	30 W	40 W	60 W
Heating element	Nichrome heater			
Standard tip	ø3 x 65 mm (No.BB3)	ø4 x 70 mm (No.BB4)		ø6 x 85 mm (No.BB6)
Total length*	199 mm	207 mm		248 mm
Weight*	60 g	65 g		95 g

\* Without cord

### Option

Part No.	Name	Specifications
602	Iron holder	With cleaning sponge
603	Iron holder	With cleaning sponge

\* For information on the iron holders, see P.60.

**HAKKO MG**  
SOLDERING GUN

## Solder Feed Soldering Gun

Tip included



- Solder feed mechanism built in the body allows users to make fine adjustments.



### Specifications

Model No.	582	583	585	587	589	592
Power consumption	30 W	40 W	60 W	80 W	100 W	150 W
Heating element	Nichrome heater					
Standard tip	ø4 mm (No.582-T-4)	ø6 mm (No.585-T-6)	ø8 mm (No.587-T-8)		ø10 mm (No.592-T-10)	
Dimensions	197 x 149 mm	213 x 149 mm	227 x 149 mm		241 x 149 mm	
Weight*	266 g	290 g	318 g	322 g	380 g	

\* Without cord

### Packing List

<b>582, 583, 585, 587, 589, 592</b>	Unit, 1.6 mm diameter Guide nozzle, Instruction manual
-------------------------------------	--

\* 2.3 mm diameter guide nozzle is originally set into the unit.

### Option

Part No.	Name	Specifications
582-N-0.8	Guide nozzle	0.8 mm
582-N-1.0	Guide nozzle	1 mm
582-N-1.2	Guide nozzle	1.2 mm
607	Iron holder	With cleaning sponge
582-022	Spool holder	-

\* For information on the iron holder, see P.60.

## HAKO FX-301B SOLDERING POT ESD SAFE

High Performance Soldering Pot **Digital**



- Digital display ensures reliable temperature control and realizes precise temperature adjustment.
- Soldering pot is coated in a special long-life material, which is best suited for lead-free solder. This is provided as a standard feature.

## HAKO FX-300 SOLDERING POT

High Performance Soldering Pot **Analog**



- Temperature can be adjusted just by turning a knob during operation.
- Adding an optional specially coated stainless-steel pot provides compatibility with lead-free solder.

## Quick Heat Up

### Time comparison to reach set temperature

#### FX-301B vs. HAKKO 96 (conventional model)

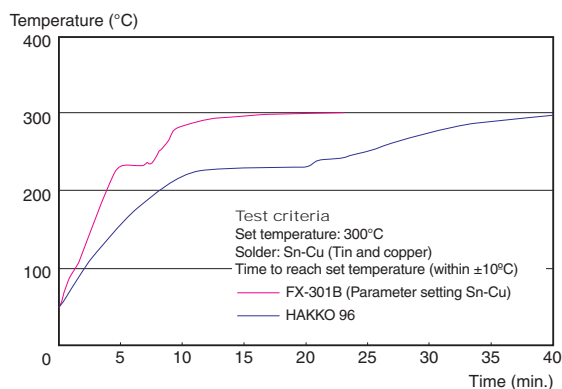

#### FX-300 vs. HAKKO 96 (conventional model)

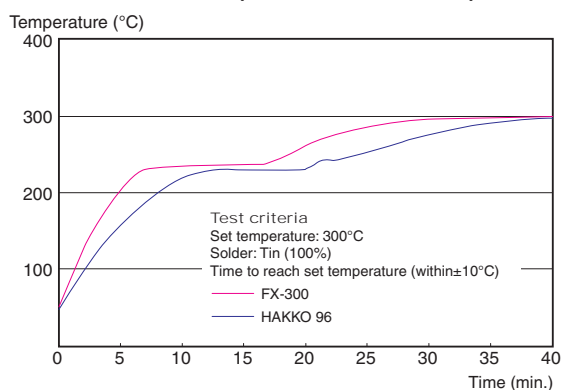

## Easy Pot Replacement



Loosen the screw on both sides.



Change the pot and tighten the screws.

\* For your safety, be sure to replace the pot after the solder completely cools.

## Specially Coated Solder Pot (Durable type)

The special coating prevents the solder pot from corroding, which ensures that the solder pot has a long service life.



Standard solder pot



Specially coated solder pot

## Packing List

<b>FX-301B</b>	Unit (with solder pot, 50 × 50 durable type), Spatula, J-shaped waste collector, Hexagon wrench, Instruction manual
<b>FX-300</b>	Unit (with solder pot, 50 × 50), Spatula, J-shaped waste collector, Hexagon wrench, Instruction manual

## Specifications

Model No.	FX-301B
Power consumption	200 W (100 V), 260 W (110 V), 290 W (120 V), 240 W (220 V), 260 W (230 V), 280 W (240 V)
Dimensions	143 (W) × 100 (H) × 220 (D) mm
Weight*	1.7 kg

### Pot

Temperature range	50 × 50 square: 200 to 450°C 75 × 75 square: 200 to 380°C
Dimensions of solder pot	50 × 50 square durable type: 50 (W) × 42.2 (H) × 50 (D) mm 75 × 75 square durable type: 75 (W) × 51.2 (H) × 75 (D) mm
Molten solder capacity**	50 × 50 square: 0.85 kg 75 × 75 square: 1.2 kg

Model No.	FX-300
Power consumption	195 W (100 V), 220 W (110 V), 200 W (120 V), 190 W (220 V), 205 W (230 V), 215 W (240 V)
Dimensions	143 (W) × 100 (H) × 220 (D) mm
Weight*	1.7 kg

### Pot

Temperature range	50 × 50 square: 200 to 450°C 75 × 75 square: 200 to 380°C
Dimensions of solder pot	50 × 50 square standard type: 50 (W) × 42.2 (H) × 50 (D) mm 75 × 75 square standard type: 75 (W) × 51.2 (H) × 75 (D) mm
Molten solder capacity**	50 × 50 square: 0.85 kg 75 × 75 square: 1.2 kg

\* Without solder and cord

\*\* The 50 × 50 square solder pot is originally installed. The 75 × 75 square solder pot is an optional part.

## Option / Replacements

Part No.	Name	Specifications
A1539	Solder pot	50 × 50 durable type
A1540	Solder pot	75 × 75 durable type
A1517	Solder pot	50 × 50 standard type
A1518	Solder pot	75 × 75 standard type
A1310	Temperature probe	For solder bath and pot

## Dimensions of Solder Pot

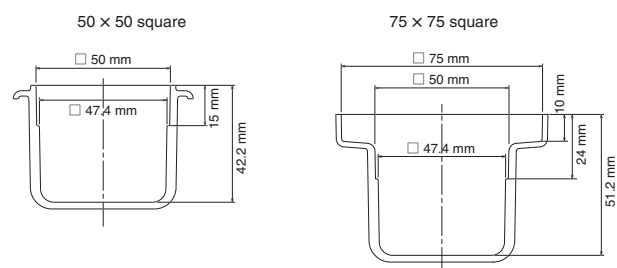

# Soldering Pot and Flow Soldering System

## HAKKO 96 SOLDERING POT

### Soldering Pot



- Temperature can be adjusted just by turning a knob during operation.

#### Features

##### Dimensions of Solder Pot

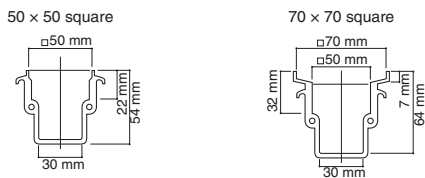

##### Operation



#### Packing List

96, 96-1	Unit, Spatula, Instruction manual
----------	-----------------------------------

#### Specifications

Part No.	96	96-1
Power consumption	200 W	
Dimensions	135 (W) × 105 (H) × 224 (D) mm	135 (W) × 120 (H) × 224 (D) mm
Weight*	1.5 kg	1.6 kg
Temperature range	100 to 450°C	100 to 380°C
Dimensions of solder pot	50 (W) × 54 (H) × 30 (D) mm	70 (W) × 64 (H) × 30 (D) mm
Molten solder capacity	0.85 kg	1.2 kg

\* Without cord

## HAKKO 485 SOLDERING SYSTEM

### Flow Soldering System



- Compatible with lead-free solder
- The impeller and chamber, which are the parts that corrode most easily, are plated with corrosion-resistant material.
- Both temperature and time are used to control the solder flow.

#### Dimensions

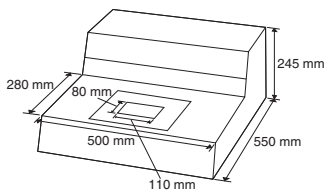

#### Specifications

Model No.	485
Power consumption	850 W
Temperature range	Room temperature to 300°C
Molten solder capacity	10 kg
Dimensions	500 (W) × 245 (H) × 550 (D) mm
Weight*	35 kg

##### Air unit

Air pressure	196 to 686 kPa (2 to 7 kgf/cm <sup>2</sup> )
Dimensions	150 (W) × 100 (H) × 300 (D) mm
Weight**	3.5 kg

\* Without solder and cord

\*\* Without cord

#### Packing List

485

Main unit, Air unit, Lamp (10 W [6 V]), Horizontal gauge, Spatula, IC tweezers, Waste collector, Positioning board, Foot switch, Locator light, Anti-oxidizer, 42-pin nozzle, 28-pin nozzle, 18/20-pin nozzle, 14/16-pin nozzle, 42-pin air hood, 28-pin air hood, 18/20-pin air hood, 14/16-pin air hood, Instruction manual

\* Solder is not included.

## HAKKO 375 SELF FEEDER

### V-Groove Maker



- Cutting a V-groove put on the solder surface reduces the splash of solder and flux.
- The solder feed amount can be controlled by turning the switch on and off.
- Compact, space-saving automatic solder feeder

### Features

#### Minimize solder and flux splash

Cutting a V-groove on the solder surface enables the release of gas pressure generated by the flux, thereby suppressing splash. HAKKO 375 can cut a groove in only the solder needed, then helps to reduce the level of defectiveness.

#### Advantages of V-grooved solder

-Examination of solder and flux splash

Solder cross-section view

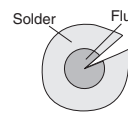

3D view

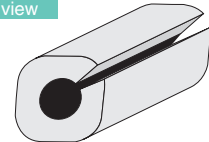

V-grooved solder

#### Test criteria

Measurement method	Measure the amount of solder and flux splashing after solder is fed to the soldering iron
Temperature setting for soldering iron	350°C and 400°C
Solder	Lead-free (Sn-3Ag-0.5Cu) Halogen-free flux ø0.3 mm and ø1 mm
Solder feed length	50 mm

\* The effect of solder and flux splashing prevention may differ under different operation conditions.

#### Amount of flux splashing (quantity of dots)

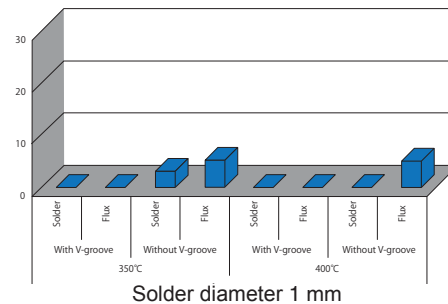
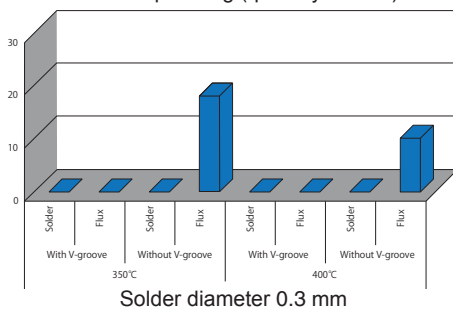

### Packing List

375	Unit, AC Adapter, Instruction manual
-----	--------------------------------------

### Option

Part No.	Name
B1649	Foot switch
B2763	Hand switch

### Specifications

Model No.	375
Rating	DC 24 V 75 mA
Solder feed speed	27 mm/sec.
Usable solder diameter	ø0.3, 0.5, 0.6, 0.8, 1 mm
Dimensions	78 (W) × 98 (H) × 56 (D) mm
Weight	0.59 kg

#### AC Adapter

Output voltage	DC 24 V
----------------	---------



**HAKKO 373** SELF FEEDER **ESD SAFE**

## Self Feeder

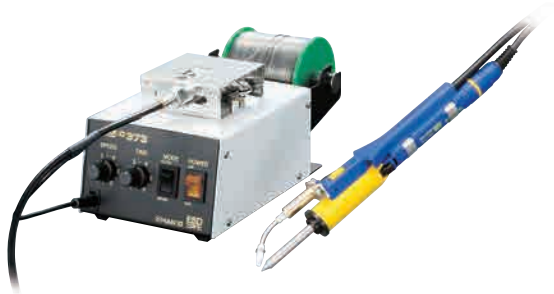

- Automatic solder feeder that enables a user to complete soldering work with just one hand
- The solder feed time and speed can be set.

### Set-Up Example

#### •Soldering for one-handed operation

Soldering irons + HAKKO 373 + Solder diameter adjustment ring + Tube unit with switch or Guide pipe assembly or

\* See the applicable soldering irons in the P.53.

Set-up example

#### •Soldering with a feeder pen

Soldering irons + HAKKO 373 + Solder diameter adjustment ring + Feeder pen + Switch or Foot switch or Feeder switch

\* Compatible with all soldering irons

Set-up example

### Specifications

Model No.	373
Power consumption	6 W
Solder feed time	0 to 7 sec. (auto mode)
Solder feed speed	4.5 to 26 mm/sec.
Solder feed quantity	0 to 182 mm
Solder return quantity	0 to 5 mm (fixed speed)
Mode	Auto and manual
Usable solder diameter*	ø0.6, 0.65, 0.8, 1, 1.2, 1.6 mm
Usable solder quantity	1 kg or less
Dimensions	107 (W) × 110 (H) × 215 (D) mm
Weight**	1.5 kg

\* ø1.6 mm lead free solder can't be used.

\*\* With cord

### Packing List

373	Unit, Instruction manual
-----	--------------------------

The accessories that are required for initial set-up, such as a tube unit, guide pipe assembly, and solder diameter adjustment ring, are not included. They must be ordered separately and adapted to use with the soldering iron and solder wire diameter.

## Accessory Selection Guide

### ■ One-handed operation

Applicable soldering iron	Solder feed unit	Solder diameter	Options		
			Solder diameter adjustment ring	Guide pipe assembly	Tube unit
FM-2027 FM-2028 	373	0.6, 0.65 mm	 B1626	 or 	 or 
		0.8 mm	B1627	B3482	
		1 mm	B1628	B3483	
		1.2 mm	B1629	B3484	B3478
FM-2030 	373	0.6, 0.65 mm	B1626	B3726	B3477
		0.8 mm	B1627	B3727	
		1 mm	B1628	B3728	
		1.2 mm	B1629	B3729	B3478
FX-1001  <small>* The spacer No.B5183 is required separately.</small>	373	0.6, 0.65mm	B1626	B3481	B3477
		0.8mm	B1627	B3482	
		1mm	B1628	B3483	
		1.2mm	B1629	B3484	B3478
FX-8002 	373	0.6, 0.65mm	B1626	B5072	B3477
		0.8mm	B1627	B5073	
		1mm	B1628	B5074	
		1.2mm	B1629	B5075	B3478
FX-8301 	373	0.6, 0.65 mm	B1626	B3566	B3563
		0.8 mm	B1627	B3567	
		1 mm	B1628	B3568	
		1.2 mm	B1629	B3569	B3564
		1.6 mm	B1630	B3570	
FX-8801 	373	0.6, 0.65 mm	B1626	B2146	B2143
		0.8 mm	B1627	B2147	
		1 mm	B1628	B2148	
		1.2 mm	B1629	B2149	B2144
		1.6 mm	B1630	B2150	
FX-8805 	373	0.6, 0.65 mm	B1626	B2151	B2143
		0.8 mm	B1627	B2152	
		1 mm	B1628	B2153	
		1.2 mm	B1629	B2154	B2144
		1.6 mm	B1630	B2155	

### ■ Feeder pen

Applicable soldering iron	Solder feed unit	Solder diameter	Options		
			Solder diameter adjustment ring	Feeder pen	Switch
Compatible with all soldering irons	373	0.6, 0.65 mm	 B1626		 or 
		0.8 mm	B1627		
		1 mm	B1628		
		1.2 mm	B1629		
		1.6 mm	B1630	C1235	

## HAKOFT-801 THERMAL WIRE STRIPPER ESD SAFE

### Thermal Wire Stripper

Blade not included



- Thermal wire stripper that ensures clean-cut removal of wire insulation
- High stripping performance ensures clean cut through highly heat-resistant PTFE.

### Features

Solves the problem of whiskers and scratches being left by conventional tools

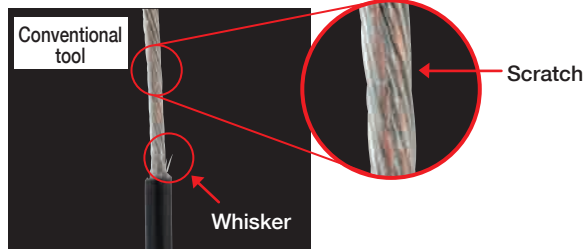
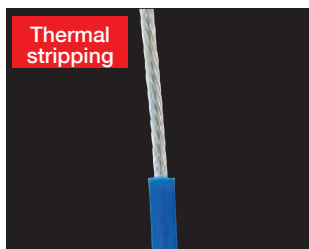

### Replacement Blades

Unit: mm

For FT-8002

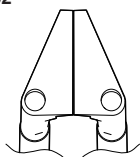

G2-1601 Wire stripper blade  
Straight

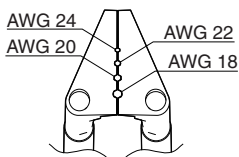

G2-1602 Wire stripper blade  
AWG 18 to 24

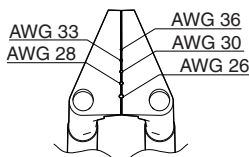

G2-1603 Wire stripper blade  
AWG 26 to 36

For FT-8003 (option)

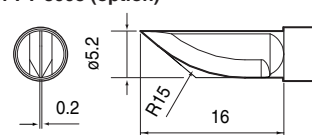

G3-1601 Knife type blade

### Packing List

FT-801	Station, Handpiece (FT-8002), Power cord, Handpiece holder, Connecting cable, Lead adjuster, Blade removal tool, Instruction manual
--------	---

### Option

Part No.	Name	Specifications
FT8003-01	FT-8003 conversion kit	Handpiece (FT-8003), Knife blade, Handpiece holder, Instruction manual



Blade included



### Specifications

Model No.	FT-801
Power consumption	68 W/50 W*
<b>Station</b>	
Output voltage	AC 24 V
Dimensions	80 (W) × 130 (H) × 131 (D) mm
Weight**	1.2 kg
<b>Handpiece</b>	
Power consumption	64 W (24 V)
Cord length	1.3 m
Total length***	96 mm
Weight***	48 g

\* When connecting with FT-8003

\*\* Without cord

\*\*\* Without cord and blade

# HAJKO CUTTING TOOL

## Cutting Tool



- Designed for precision assembly of delicate, complex electronic work
- Soft-touch grip enables long tool usage for long periods at a time.
- Use in cutting copper and soft lead wires (do not use on hard drawn steel wires.)

MAX.Cu = Max. annealed copper lead wire cutting capability

**Cutting tool for flush cut with safety clip**



Part No. 106-01

**Cutting tool for flush cut with angled blade**



Part No. 106-02

**Cutting tool for flush cut with small blade**

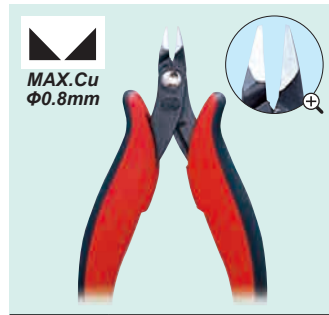

Part No. 106-03

**Cutting tool for a front, flush cut**

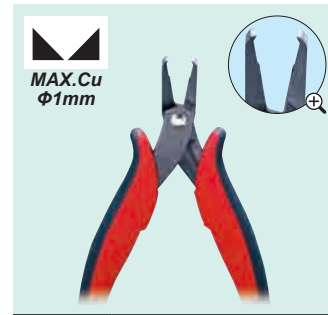

Part No. 106-04

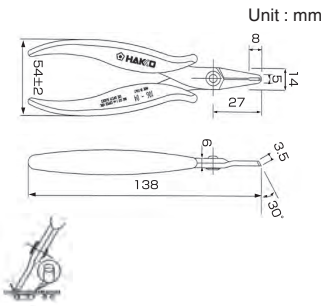
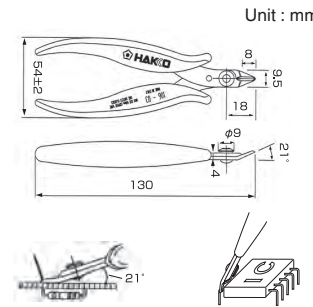
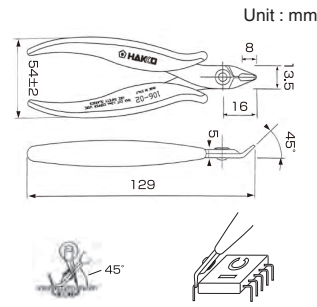
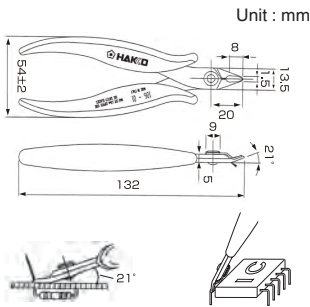

**Cutting tool for flush cut**



Part No. 106-05

**Short nose pliers**

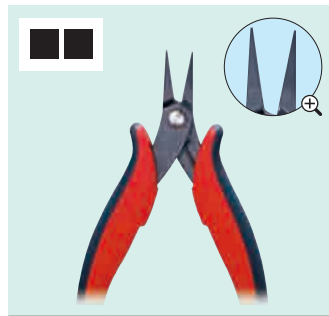

Part No. 106-06

**Long nose pliers**

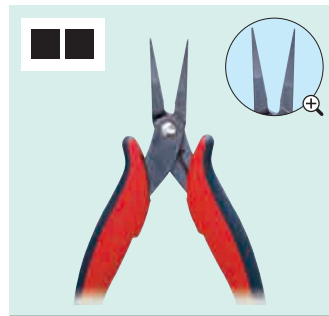

Part No. 106-07

**Bent nose pliers**

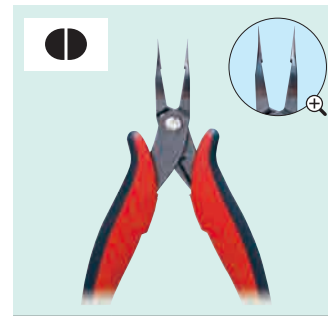

Part No. 106-08

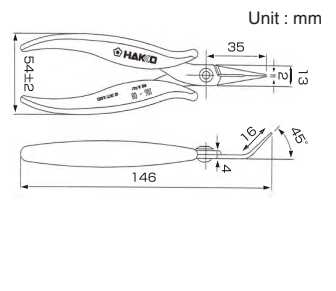
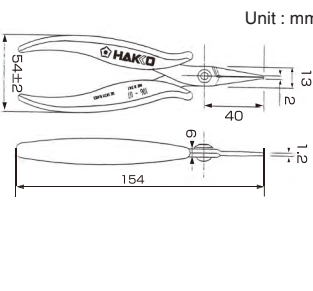
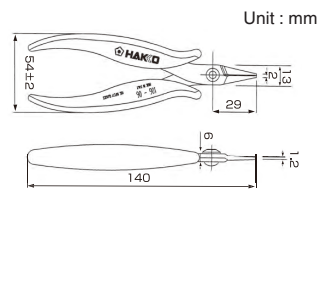
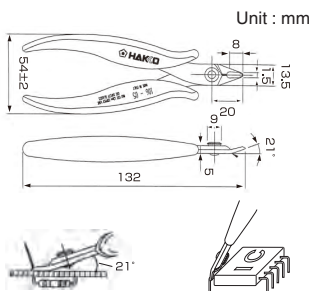

## HAKKO 153·154 LEAD FORMER

### Lead Cutter and Former

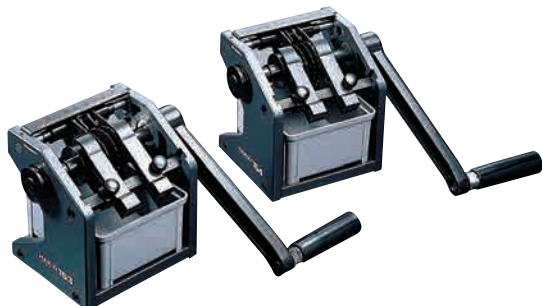

- Lead cutter and former for axial components
- Can be used for forming and cutting, forming only, or cutting only

### Cutting and Forming

HAKKO 153	HAKKO 154
<p>Cutting and forming</p>	<p>Cutting and forming</p>
<p>Forming</p>	<p>Forming</p>
<p>Cutting</p>	<p>Cutting</p>

### Packing List

153, 154

Unit, Parts tray, Clamp, Handle, 2 mm Hexagon wrench, 2.5 mm Hexagon wrench, 3 mm Hexagon wrench, 4 mm Hexagon wrench, Instruction manual

### Specifications

Part No.	153-1	154-1
Forming size	5.6 mm pitch	5 mm pitch
Diameter of lead wire	ø0.8 mm (max.)	ø0.5 mm (max.)
Lead wire*	For annealed copper lead wire only	
Outer width of tape	85 mm (max.)	
Taping pitch	5 mm	
Dimensions	125 (W) × 130 (H) × 110 (D) mm	
Weight**	2 kg	

\* These tools are not suited to work on components with lead frames (square lead).  
\*\* Including handle and clamp

## HAKKO 155 LEAD CUTTER

### Lead Cutter



- Lead cutter for radial components

### Packing List

155

Unit, Parts tray, Clamp, Handle, 2 mm Hexagon wrench, 2.5 mm Hexagon wrench, 3 mm Hexagon wrench, 4 mm Hexagon wrench, Instruction manual

### Specifications

Part No.	155-1	155-2
Diameter of lead wire	ø0.8 mm (max.)	
Lead wire*	For annealed copper lead wire only	
Processing part size	ø12.5 × 25 mm (max.)	ø15 × 25 mm (max.)
Feed hole pitch	12.7 mm	15 mm
Lead pitch**	5 mm, 2.5 mm	5 mm
Processing size	1.5 mm from taping end, 2 mm from component end (min.)	
Dimensions	110 (W) × 140(H) × 125 (D) mm	
Weight***	1.7 kg	

\* These tools are not suited to work on components with lead frames (square lead).  
\*\* When shipped, the unit is set for components with a lead pitch of 5 mm.  
\*\*\* Including handle and clamp

### Cutting

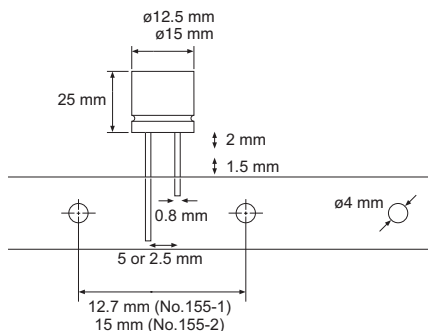

\* Cutting only



# HAKKO 152B

MOTOR DRIVE

## Motor Drive



Lead cutter or former is not included in HAKKO 152B.

### Packing List

152B	Unit, Instruction manual
------	--------------------------



- Motor drive that enables automatic cutting and forming of taped components
- Constant-torque drive ensures precise and speedy processing.
- Speed control knob enables the adjustment of the processing speed.

### Specifications

Model No.	152B
Power consumption	30 W
Processing capacity (with HAKKO 153, 154)	50 Hz : 30,000 pcs/hr (max.) 60 Hz : 36,000 pcs/hr (max.)
Processing capacity (with HAKKO 155)	50 Hz : 15,000 pcs/hr (max.) 60 Hz : 18,000 pcs/hr (max.)
Dimensions	430 (W) × 140 (H) × 150 (D) mm
Weight*	5.6 kg

\* Without cord

# HAKKO DIPLINER

LEAD STRAIGHTENER

## Lead Straightener



- IC lead liner for correcting variable lead pitches
- Simple mechanism enables the adjustments with just one screw.
- Simply insert the IC case into the chute.

### Packing List

FT100, FT150, FT200, FT300	Unit, Instruction manual
----------------------------	--------------------------

### Specifications

Part No.	FT100	FT150	FT200	FT300
Width of IC	7.5 mm	10 mm	15 mm	19 mm
Number of IC leads	8, 14, 16 18, 20	22	24, 28 40, 42	64

## HAKKO FT-710 ESD SAFE TIP CLEANER

### Solder-Splash-Preventing Rotary Tip Cleaner





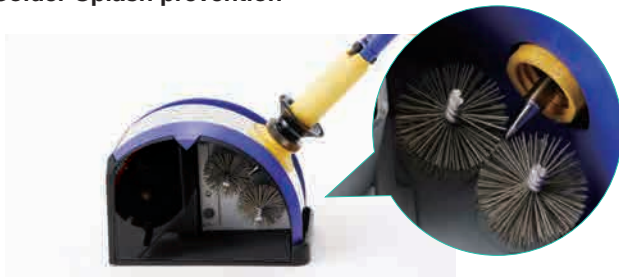

- The solder removal level can be adjusted using two different types of brushes.
- Brushes can be replaced without using any tools, and safe design prevents solder waste from entering the drive part.

#### Features

##### Solder-Splash prevention



##### Controllable solder removal level

Brush	Cleaning brush A (standard accessory)	Cleaning brush B (optional)
Material	Resin 	Metal 
Image after cleaning	Some solder remains. 	Solder is completely removed. 
Benefit	Prevents tip oxidation and extends the service life of the tip	Suitable for soldering small sections that require control over the amount of solder.

##### Minimizes decrease in temperature of the tip during cleaning

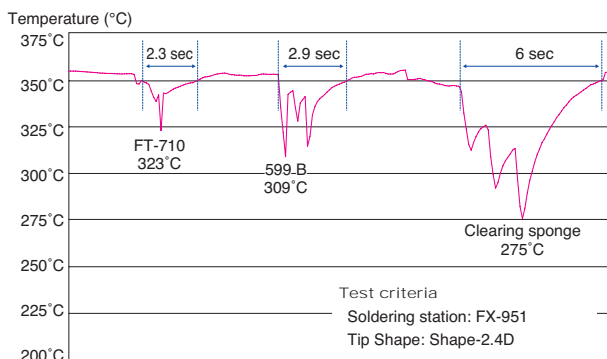

#### Packing List

FT-710	Unit, AC adapter, Receptacle A, Receptacle B, Lock nut, Gauge, Instruction manual
--------	---

#### Specifications

Model No.	FT-710
Rating	DC 24 V 130 mA
Brush rotational speed	2500 rpm
Standard receptacle	Receptacle A and B
Dimensions	71 (W) × 77 (H) × 107 (D) mm
Weight	450 g

#### AC adapter

Output voltage	DC 24 V
----------------	---------

#### Compatibility table

Tip	Receptacle A	Receptacle B	Receptacle C
T12, T11	✓		
T18, 900M		✓	
T20, T13, T22			✓

\* This cleaner cannot be used with T12-JL02, quad type, tunnel type, and spatula type soldering tips of T12 series.

\* It can be used with T19 series, only with the use of a custom-ordered receptacle. In this situation, consult your nearest HAKKO dealer or distributor.

\* It cannot be used with FX-8802 and FX-8803 with T18 series.

\* There are some tips with dimensions that cannot be adjusted with the standard receptacles. In this situation, consult your nearest HAKKO dealer or distributor.

#### Option

Part No.	Name	Specifications
A1567	Cleaning brush B	Metal brushes, set of 2
B3519	Receptacle C	—

## HAKKO FT-700 TIP POLISHER

### Tip Polisher



- Soldering tip polisher best suited to the removal of carbide and oxide on soldering tips
- Prevents the shortening of the service life of tips caused by oxidation

### Usage

#### Cleaning procedure



Use the brush to remove tough oxide.

## HAKKO FS-100 CHEMICAL PASTE

### Chemical Paste



- Chemical paste best suited to the removal of oxide on soldering iron tips
- Also used for re-tinning of soldering tips

### Packing List

FS-100	Paste, Instruction manual
--------	---------------------------

### Packing List

FT-700	Unit, Paste, Brush, Instruction manual
--------	--

### Specifications

Model No.	FT-700
Power consumption	3 W (100 V), 4.5 W (110 to 120 V, 220 to 240 V)
Dimensions	70 (W) × 54 (H) × 101 (D) mm
Weight*	0.65 kg

\* Without cord

#### Chemical paste

Amount	10 g
Ingredients	Flux, tin (Sn) 50 wt% (each)

\* The flux component of chemical paste consists of alicyclic amine hydrobromate, aliphatic amine hydrobromate, petrolatum, and wax.

\* Make sure the tip is cleaned after use according to the procedure shown in the left.

\* Do not use the chemical paste for purpose other than restoring of the soldering tip.

### Specifications

#### Chemical paste

Amount	10 g
Ingredients	Flux, tin (Sn) 50 wt% (each)

\* The flux component of chemical paste consists of alicyclic amine hydrobromate, aliphatic amine hydrobromate, petrolatum, and wax.

\* Make sure the tip is cleaned after use according to the procedure shown above.

\* Do not use the chemical paste for purpose other than restoring of the soldering tip.

## HAKKO IRON HOLDER

### Iron Holder



No.FH300-81\*



No.633-01



No.633-02

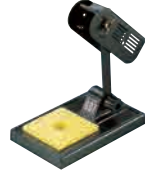

No.607



No.602



No.603

\* HAKKO 599B can be also mounted.

### Wire-type tip cleaner



No.599B



HAKKO 599B

Prevents soldering tip oxidation

### Applicable Soldering Irons

Part No.	FH300-81	633-01	633-02	607	602	603
Soldering irons	DASH PRESTO FX-600 FX-601	DASH PRESTO FX-600 FX-601	DASH PRESTO FX-600 FX-601	MG	RED	RED

## HAKKO 611 ESD SAFE SOLDER REEL STAND

### Reel Stand



No.611-2



- Solder reel stand for coiled solder with a maximum load of 1 kg
- Smooth action when reeling out solder wire improves work efficiency
- A mounting screw for the grounding wire is attached on the baseplate.

### Specifications

Part No.	611-1	611-2
Shaft diameter	ø15 mm	
Usable solder	Roll solder 1 kg (max.) × 1	Roll solder 1 kg (max.) × 2
Dimensions	87 (W) × 78 (H) × 141 (D) mm	87 (W) × 200 (H) × 141 (D) mm
Weight	450 g	750 g

## HAKKO FS-210

SOLDERING FLUX

### Brush-tip Type Flux Pen



- Pen tip does not split easily.
- You can fill your favorite flux into FS-210.
- Simply push the pen shaft when you need some extra flux.

#### Features

Pen for pinpoint application of optimum amount of flux

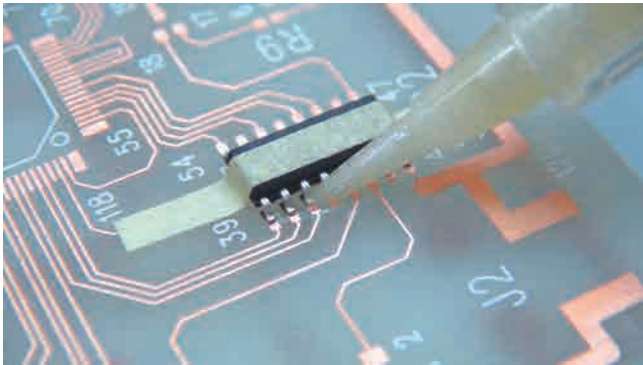

Simply push the shaft for a generous coating of flux



#### Packing List

FS210-82	Flux container for 4 mL (5 pcs)
----------	---------------------------------

\* No Flux contained.

#### Replacement Parts

A5009	Brush-tip with a cap (5 pcs)
-------	------------------------------





# Vacuum Pick-Up Tool

## **HAKKO392** ESD SAFE VACUUM PICK-UP

### Outlet-Powered Type



- Outlet-powered suction pick-up tool with built-in vacuum pump
- The pick-up capacity can be increased up to 230 gf with an optional pad.

## **HAKKO393** VACUUM PICK-UP

### Dropper Type



- Portable, easy-to-carry manual dropper-type vacuum pick-up
- Maximum pick-up capacity of 40 gf
- Uses antistatic material

## **HAKKO394** VACUUM PICK-UP

### Battery-Powered Type



- Battery-powered suction pick-up tool with built-in vacuum pump
- Maximum pick-up capacity of 120 gf
- Uses antistatic material

## Usage Example

### HAKKO 392



### HAKKO 393



### HAKKO 394



With the bent nozzle accessory, 0603-size components can be picked up.



## Replacement Pads and Nozzles

Part No.	Name	Specifications
A1164	Bent nozzle	0.4 mm
A1165	Bent nozzle	1.1 mm with stopper
A1198	Bent nozzle	0.26 mm
A1486	Straight nozzle	1.1 mm with stopper
A1166	Pad	3 mm
A1312	Pad	5 mm
A1167	Pad	7 mm
A1311	Pad	10 mm

## Packing List

<b>392</b>	Unit, $\varnothing$ 0.4 mm Bent nozzle, $\varnothing$ 1.1 mm Bent nozzle, $\varnothing$ 3 mm Pad, $\varnothing$ 7 mm Pad, Instruction manual
<b>393</b>	Unit, $\varnothing$ 1.1 mm Bent nozzle with stopper, $\varnothing$ 3 mm Pad, $\varnothing$ 7 mm Pad, $\varnothing$ 10 mm Pad, Instruction manual
<b>394</b>	Unit, $\varnothing$ 1.1 mm Bent nozzle with stopper, $\varnothing$ 5 mm Pad, $\varnothing$ 10 mm Pad, two AAA Alkaline batteries (for trial), Instruction manual

## Specifications

Model No.	392
Power consumption	5 W
Maximum pressure	37.3 kPa (280 mmHg)
Pad	Conductive silicone rubber
Dimensions	Station: 132 (W) $\times$ 83 (H) $\times$ 170 (D) mm Pen: $\varnothing$ 10 $\times$ 123 (L) mm Hose: 1.1 m
Weight*	Station: 1.65 kg Pen: 25 g

\* Without cord, nozzle and pad

Model No.	393
Pad	Conductive silicone rubber
Dimensions	$\varnothing$ 13 mm $\times$ 132 mm
Weight*	19 g

\* Without nozzle and pad

Model No.	394
Power supply	Two AAA batteries
Pad	Conductive silicone rubber
Battery life	Approx. 30,000 suction cycles (with alkaline batteries)
Suction capacity	120 gf (with a pad diameter of 10 mm)
Dimensions	130 (W) $\times$ 29 (H) $\times$ 22 (D) mm
Weight*	43 g

\* Without batteries, nozzle and pad

## HAKKO FR-301 New

### Portable Desoldering Tool

Nozzle included



- Power switch and adjustable temperature control built in the handle
- Use of high thermal efficiency N61 series nozzles
- Reduction of solder clogging by improved heating core (in comparison with the previous model)

### Packing List

<b>FR-301</b>	Unit, Pre-filter, Ceramic paper filter (L, qty 2), Nozzle wrench, Iron holder (simple type), Cleaning pin for heating core, Cleaning pin for $\phi 1$ mm nozzle, Instruction manual
---------------	---



Provided in a carrying case

### Specifications

Model No.	FR-301
Power consumption	100 V 98 W (50/60 Hz) 110 V 122 W (50/60 Hz) 120 V 140 W (60 Hz) 220 V 100 W (50/60 Hz) 230 V 110 W (50/60 Hz) 240 V 120 W (50/60 Hz)
Temperature range	350 to 500 °C
Nozzle to ground resistance	<2 $\Omega$
Nozzle to ground potential	<2 mV
Vacuum generator	Diaphragm pump
Vacuum pressure	81 kPa (610 mmHg)
Suction flow	11 L/min.
Heating element	Ceramic heater
Standard nozzle	$\phi 1$ mm (No.N61-08)
Dimensions	215 (W) $\times$ 226 (H) mm (with $\phi 1$ mm (No.N61-08) nozzle)
Weight*	0.52 kg (with $\phi 1$ mm (No.N61-08) nozzle)

\* Without cord

## Features

### Easy temperature control

LED indicators let you easily see when the heater is active and idling at your temperature setting.

- Temperature range
- Setting 1 350°C
- Setting 2 400°C
- Setting 3 450°C
- Setting 4 500°C

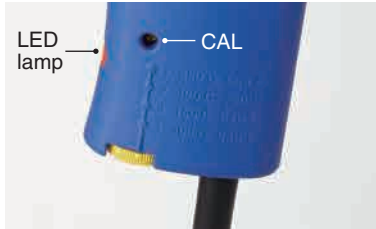

### A wide selection of nozzles (N61 series)

SS type nozzles  
for micro land patterns



Oval shape nozzles  
for flat terminals



Long type nozzles  
for narrow space



### Quick-change nozzle replacement with special tools

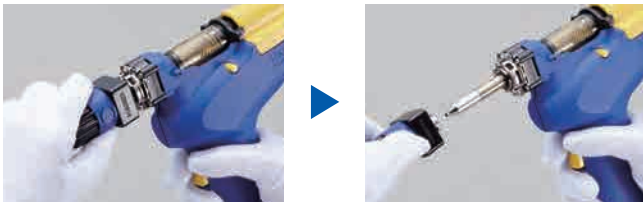

### Reduction of solder clogging by improved heating core

This additional guard prevents a temperature drop of the heating core by making contact with the front holder and it enables to reduce solder clogging.

\* In comparison with the previous model

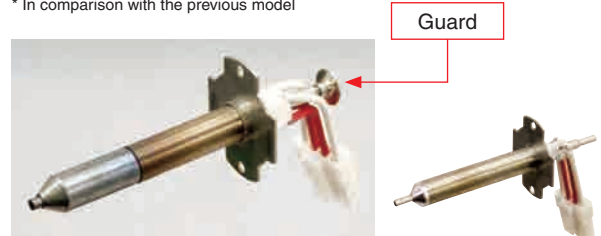

Heating core of  
the previous product  
(FR-300)

## Replacement Nozzles

Unit : mm

<b>SS type</b>	<b>N61-01</b>	<b>N61-02</b>	<b>N61-03</b>	
<b>S type</b>	<b>N61-04</b>	<b>N61-05</b>	<b>N61-06</b>	
<b>Standard type</b>	<b>N61-07</b>	<b>N61-08</b>	<b>N61-09</b>	<b>N61-10</b>
<b>Long type</b>	<b>N61-11</b>	<b>N61-12</b>	<b>N61-13</b>	<b>N61-14</b>
<b>Oval type</b>	<b>N61-15</b>	<b>N61-16</b>		

\* N61 series nozzles can also be used for FR-410 desoldering station.

# Desoldering Tool

## HAJKO FR-400 DESOLDERING TOOL ESD SAFE



### Heavy Duty Desoldering Tool Digital

Nozzle included

Power Consumption  
**300 W**



- 300 W heavy duty desoldering tool with built-in vacuum pump
- Secure desoldering with valve function
- Reduction of solder clogging
- Improvement in maintainability

## HAJKO FR-410 DESOLDERING TOOL ESD SAFE

### High-Power Desoldering Tool Digital

Nozzle included

Power Consumption  
**140 W**



- 140 W high power enables perfect desoldering for the components on multi-layer P.W.B.
- A wide selection of nozzles is available for a variety of desoldering works.



### Feature of FR-400

300 W tremendous power makes incredible heating.

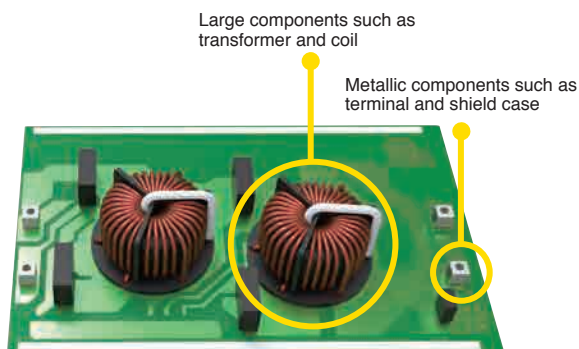

### Feature of FR-410

A wide selection of nozzles is available for a variety of desoldering works.

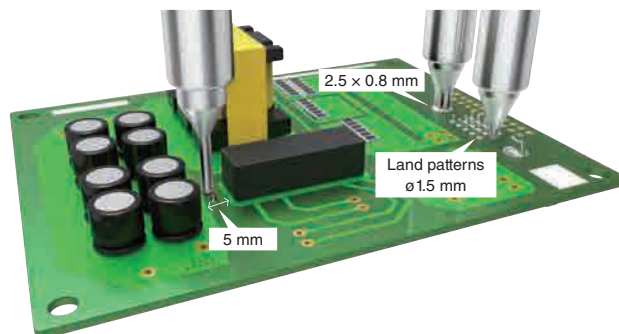

### Common Features of FR-400 and FR-410

#### Secure desoldering, valve function that suctions with high pressure

Suction starts 0.2 seconds after pulling the trigger for instance and high pressure suction to achieve complete desoldering.

#### Improvement in heating core

Heating ability for backside of heating core is increased to ensure suctioned solder be carried to filter pipe and avoid solder clogging.

#### Featuring ACF (Anti Clogging Function)

ACF ensures suctioned solder be carried to filter pipe by keeping pump running for a second after releasing trigger.

#### Reduction of solder clogging by improved heating core

The additional guard prevents a temperature drop of the heating core by making contact with the front holder and it enables to reduce solder clogging.

\* In comparison with the previous model

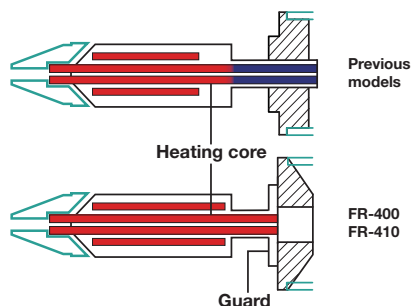

#### Improvement in maintainability

##### Easy heater replacement

##### Tool box for maintenance kit



By removing 3 screws



##### Filter pipe for easy maintenance

\* This picture shows FR-410 filter pipe.

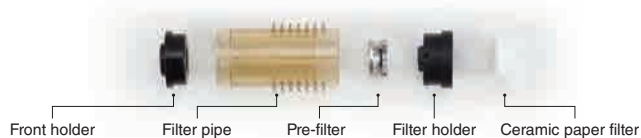

### Specifications

Model No.	FR-400	FR-410
Power consumption	320 W	190 W
Temperature range	350 to 500 °C	330 to 450 °C
Temperature stability	±5 °C at idle temperature	±5 °C at idle temperature

#### Station

	FR-400	FR-410
Output voltage	AC 29 V	AC 24 V
Vacuum generator	Vacuum pump, double cylinder type	Vacuum pump, double cylinder type
Vacuum pressure	80 kPa (600 mmHg, max.)	80 kPa (600 mmHg, max.)
Suction flow*	15 L / min.	15 L / min.
Dimensions	166 (W) × 137 (H) × 264 (D) mm	165 (W) × 137 (H) × 244 (D) mm
Weight	5.7 kg	4.8 kg

#### Desoldering Tool

	FR-400	FR-410
Power consumption	300 W (29 V)	140 W (24 V)
Nozzle to ground resistance	<2 Ω	<2 Ω
Nozzle to ground potential	<2 mV	<2 mV
Heating element	Composite heater	Composite heater
Standard nozzle	ø1 mm (No. N60-02)	ø1 mm S type (No. N61-05)
Cord length	1.2 m	1.2 m
Total length**	183 mm (with ø1 mm nozzle)	168 mm (with ø1 mm S type nozzle)
Weight**	245 g (with ø1 mm nozzle)	170 g (with ø1 mm S type nozzle)

\* The suction flow is measured at the filter case suction port of station.

\*\* Without cord and hose

### Packing List

<b>FR-400</b>	Station, Desoldering tool (FR-4001), Power cord, Iron holder (with cleaning wire), Tool box (Cleaning pin for ø1 mm, Cleaning pin for heating element, Cleaning drill for ø1 mm, Nozzle wrench, Filter [qty 2], Ceramic paper filter [qty 4]), Instruction manual
<b>FR-410</b>	Station, Desoldering Tool (FR-4101), Power cord, Iron Holder (with cleaning wire), Tool box (Cleaning pin for ø1 mm, Cleaning pin for heating element, Cleaning drill for ø1 mm, Nozzle wrench, Filter [qty 2], Ceramic paper filter L [qty 4]), Instruction manual

# Desoldering Tool

## Replacement Nozzles for FR-400

Unit : mm

<b>N60-01 Nozzle <math>\phi 0.8</math></b> 	<b>N60-02 Nozzle <math>\phi 1</math></b> 	<b>N60-03 Nozzle <math>\phi 1.3</math></b> 	<b>N60-04 Nozzle <math>\phi 1.6</math></b> 	<b>N60-05 Nozzle <math>\phi 2</math></b> 
<b>N60-06 Nozzle <math>\phi 2.6</math></b> 	<b>N60-07 Nozzle <math>\phi 3</math></b> 	<b>N60-08 Nozzle 4.2 x 1.5</b> 	<b>N60-09 Nozzle 6.2 x 1.5</b> 	

## Replacement Nozzles for FR-410

Unit : mm

<b>SS type</b> N61-01 	<b>N61-02</b> 	<b>N61-03</b> 		
<b>S type</b> N61-04 	<b>N61-05</b> 	<b>N61-06</b> 		
<b>Standard type</b> N61-07 	<b>N61-08</b> 	<b>N61-09</b> 	<b>N61-10</b> 	
<b>Long type</b> N61-11 	<b>N61-12</b> 	<b>N61-13</b> 	<b>N61-14</b> 	
<b>Oval type</b> N61-15 	<b>N61-16</b> 	<p>* N61 series nozzles can also be used for FR-301 desoldering tool.</p>		

# HAKKO FM-204 DESOLDERING TOOL ESD SAFE

## Composite-type Desoldering Tool Digital

Nozzle not included

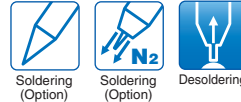

- Vacuum pump built-in type desoldering tool
- Digital display ensures easy and reliable temperature control.
- Sleep function that works with iron holder prevents nozzle oxidation.

### Packing List

FM-204	Station, Iron holder, Ceramic paper filter (10 pcs), Cleaning drill for heating element, Filter pipe assembly (1 pc), Control card, Power cord, Connecting cable, Nozzle remover, Desoldering tool (FM-2024), Handle for gun configuration, Instruction manual
--------	--

### Specifications

Model No.	FM-204
Power consumption	120 W
Temperature range	FM-2024: 350 to 450°C FM-2026/2027: 200 to 450°C
Temperature stability	±5°C at idle temperature

#### Station

Output voltage	AC 24 V
Vacuum generator	Vacuum pump, double cylinder type
Vacuum pressure	80 kPa (600 mmHg, max.)
Suction flow*	15 L/min.
Dimensions	160 (W) × 120 (H) × 225 (D) mm
Weight	3.7 kg

#### Desoldering Tool

Power consumption	70 W (24 V)
Nozzle to ground resistance	<2 Ω
Nozzle to ground potential	<2 mV
Heating element	Composite heater
Cord length	1.2 m
Total length**	180 mm (with ø1 mm nozzle)
Weight**	65 g (with ø1 mm nozzle)

\* Measured at the filter case suction port of the station.

\*\* Without cord and hose

### Features

Replacing the handpiece enables soldering.

■ Soldering

■ N<sub>2</sub> System (P.38 & P.39)



### Replacement Nozzles for FM-204

Unit : mm

<b>N1-06 Nozzle ø0.6</b> 	<b>N1-08 Nozzle ø0.8</b> 	<b>N1-10 Nozzle ø1</b> 	<b>N1-13 Nozzle ø1.3</b> 
<b>N1-16 Nozzle ø1.6</b> 	<b>N1-20 Nozzle ø2</b> 	<b>N1-23 Nozzle ø2.3</b> 	<b>N1-L10 Nozzle ø1 long</b> 

# Desoldering Tool and Wire

## HAKKO SPPON

### Desoldering Tool

Nozzle included



- Light-weight and simplified desoldering tool with high suction power
- Use a cleaning shaft that enables the nozzle to be cleaned after each use
- Nozzles can be easily replaced.

#### Replacement Nozzles

Unit : mm

Part No.	Figure	Adaptation products
18-N		No.18, 18G
20-N		No.20, 20G
DS01-N		No.DS01P

#### Specifications

Part No.	Absorption capacity
18	12 cm <sup>3</sup> (12 cc)
18G	12 cm <sup>3</sup> (12 cc) with guard
20	20 cm <sup>3</sup> (20 cc)
20G	20 cm <sup>3</sup> (20 cc) with guard
DS01P	28 cm <sup>3</sup> (28 cc)

## HAKKO WICK

### Desoldering Wire



- Handy for removing solder after dismantling surface-mounted components

#### Features

##### Through-hole solder removal



##### Bridging solder removal



#### Specifications

##### No clean type (halogen free, ESD SAFE package)

Part No.	Description
FR150-81	1.5 m × 0.7 mm
FR150-82	1.5 m × 1 mm
FR150-83	1.5 m × 1.5 mm
FR150-84	1.5 m × 2 mm
FR150-85	1.5 m × 2.5 mm
FR150-86	1.5 m × 3 mm

##### Unflux type (Unflux)

Part No.	Description
FR110-00	1.5 m × 0.6 mm
FR110-02	1.5 m × 1.4 mm
FR110-03	1.5 m × 1.9 mm
FR110-04	1.5 m × 2.5 mm
FR110-05	1.5 m × 3.3 mm

## HAKKO 851 ESD SAFE SMD REWORK STATION

### Hot-Air SMD Rework Station Analog

Nozzle included



- Single-nozzle hot air rework system that is perfect for the repair or local heating of small surface-mounted components
- Slim grip is ideal for work in narrow spaces.

### Temperature Distribution Chart

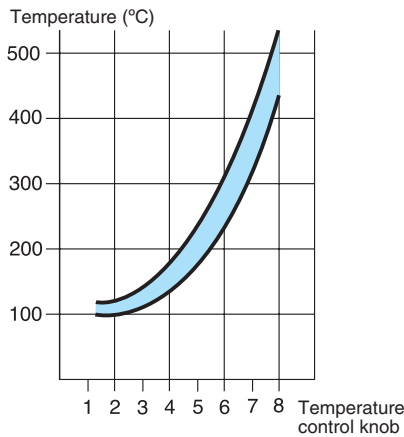

#### Test criteria

Measured at a point	2 mm from the nozzle
Room temperature	20 °C
Nozzle used	A1066 ø2 mm

### Replacement Nozzles

Part No.	Name	Specifications
A1065	Nozzle	ø1.5 mm
A1066	Nozzle	ø2 mm
A1067	Nozzle	ø3 mm
A1147	Nozzle	ø1 mm

### Packing List

851	Station with handpiece, Handpiece holder, Nozzle holder, Instruction manual
-----	---

### Specifications

Model No.	851
Power consumption	85 W
Hot air temperature	100 to 540°C

#### Station

Power consumption	5 W
Air flow	6 L/min. (max.)
Dimensions*	167 (W) × 101 (H) × 182 (D) mm
Weight*	1.8 kg

#### Handpiece

Power consumption	80 W
Standard nozzle	ø2 mm (No. A1066)
Total length**	217 mm
Weight**	180 g

\* Without cord and handpiece

\*\* Without cord



# SMD Rework Station

## HAJKO FR-810B ESD SAFE SMD REWORK STATION

Hot-Air SMD Rework Station Digital

Nozzle included



- High volume airflow and high output for a various kinds of rework
- Full digital control of temperature, airflow, and time
- Simple nozzle removal and easy maintenance
- The vacuum pick-up function with an indicator ensures safety for the components and P.W.B.'s.

## HAJKO FR-811 ESD SAFE SMD REWORK STATION

Hot-Air SMD Rework Station Digital

Nozzle not included



- Possible to make full-scale thermal profiles with 6-zone hot air and a bottom heater
- Possible to measure and record temperature of components and P.W.B. with type K thermocouple
- The dedicated software to link a station and a computer for easy and quick settings
- Easy data transfer through an USB cable

## Common Features of FR-810B and FR-811

### New user friendly functions for SMD rework

#### Pickup indicator

The indication comes up and the moment of picking up will be visible.



#### Vacuum pickup function

This can avoid an error to peel off the land by removing components with excessive force.

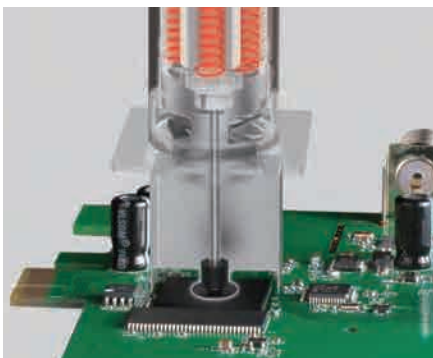

#### New type of nozzles

The new nozzles improve work efficiency with uniform heating (Only with BGA nozzles).

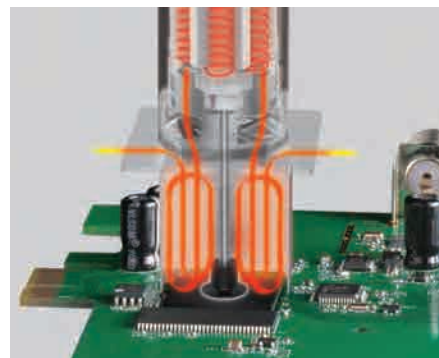

### Efficiency improvement

The high volume airflow and high output of FR-810B and FR-811 make it possible to perform the same work in only one-third of the time required when using a conventional model. This reduces the thermal impact on boards and components.

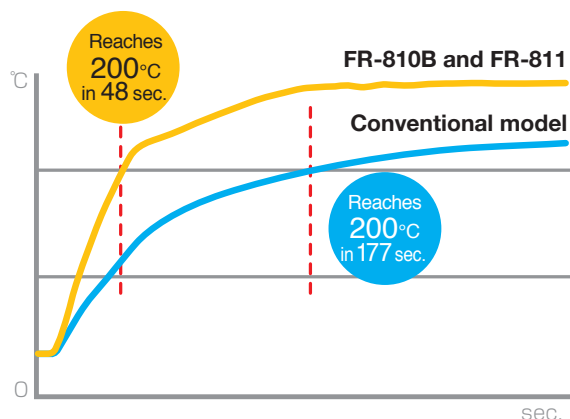

#### Test criteria

Model	FR-810B	Conventional model
Measurement method	Examination of time taken for connector sections soldered onto a ceramic board to be heated 200°C	
Board	Ceramic board	
Component used	Connector	
Nozzle shape	N51-02	A1130
Temperature setting	600°C	500°C
Air flow setting	9 (115 L/min.)	20 L/min.

### Quick-change N51 nozzles



### Simple heater replacement



## Specifications

Port No.	FR-810B	FR-811
Power consumption	700 W (100 V), 840 W (110 V), 820 W (120 V), 1100 W (220 V), 1200 W (230 V), 1300 W (240 V)	
Temperature range	50 to 600°C	

### Station

Power consumption	30 W	
Air flow*	1 to 9 (5 to 115 L/min.)	001 to 100% (5 to 115 L/min.)
Dimensions	160 (W) × 145 (H) × 220 (D) mm	
Weight	1.5 kg	

### Handpiece

Power consumption	1170 W	
Standard nozzle	ø4 mm (No. N51-02)	—
Total length**	250 mm	
Weight**	180 g	

\* Airflow capacity is rated as free flowing. Restrictions created by various nozzles may reduce the maximum airflow capacity.

\*\* Without cord

## Packing List

<b>FR-810B</b>	Station with handpiece, Nozzle (ø4 mm), Handpiece holder, Vacuum pipe control knob L (with screw), Pads (qty 2 each of ø3 mm, ø5 mm, ø7.6 mm), Heat resistant pad, Power Cord, Temperature distribution chart, Instruction manual
<b>FR-811</b>	Station with handpiece, Grip stand assembly, Vacuum pipe control knob L (with screw), Pads (qty 2 each of ø3 mm, ø5 mm, ø7.6 mm), USB cable, Software (CD-ROM), Thermocouple, Heat resistant pad, Power Cord, Temperature distribution chart, Instruction manual

## Option

Part No.	Name	Specifications
C5027	Board holder	—
C5028	Grip fixture M	With hexagon wrench, o-ring and tray
C5029	Grip fixture L	With hexagon wrench and o-ring
B5098	Board clip	—
B5136	Board support unit	—
C5013	Bottom heater	For FR-811

# SMD Rework Station

## Common Features of FR-810B and FR-811

### Auto sleep and auto shutoff features

To ensure safety and conserve power, when the handpiece is placed in the handpiece holder, the auto sleep function is activated and it starts cooling automatically.

If the handpiece has not been removed from the handpiece holder (example: using it in a rework fixture) and after it has been idle for 30 minutes, auto shutoff function is activated. It is automatically powered off.

Access to settings can be restricted via the password function for easy management.



Handpiece holder No.B5048 in the picture can be attached to FR-811 as well (option).

### Preset mode

	Preset 1	Preset 2	Preset 3	Preset 4	Preset 5
Temperature (°C)	250	300	350	400	450
Time (sec.)	100	80	50	120	150
Airflow (level)	6	7	8	4	5

### Chain presets function for making a simple thermal profile

The chain presets function is to make a simple thermal profile by combining several preset conditions (up to 5 steps).

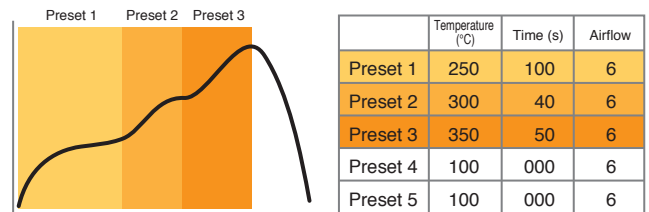

\* Presets 4 and 5 have been set to "000", so they are skipped.

## Features of FR-811

Interface designed for intuitive operation. Possible to link to a PC.



Easy-to-read LCD



Easy-to-operate multi-direction control knob



A USB device terminal for easy data transfer



Link to a PC (A USB I/F terminal available)

**The functions needed for SMD rework are in a compact body.**

**Possible to make full-scale thermal profiles with 6-zone hot air and a bottom heater**

A basic thermal profile is composed of the 5 parts shown below. FR-811 can provide 6 zones in which temperature, time, and airflow are controlled. Therefore FR-811 can make a full-scale thermal profile which is close to reflow profiles made by a reflow oven.

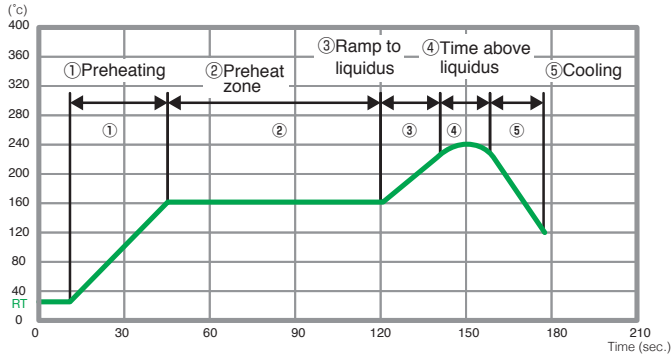

**Record thermal data**

By connecting a thermocouple included with FR-811, the temperature of the component or circuit board can be measured and recorded. In addition, if "TC LINK" is set, the heater output can be automatically controlled so that the temperature of the thermocouple attached to the component or circuit board follows the set profile.



**Operation on a PC for various settings**

By connecting FR-811 and a computer with a USB cable and using the dedicated software which comes as standard, a set thermal profile and actual temperature change can be shown in a graph in real time. The set values and graph can be saved in csv format.

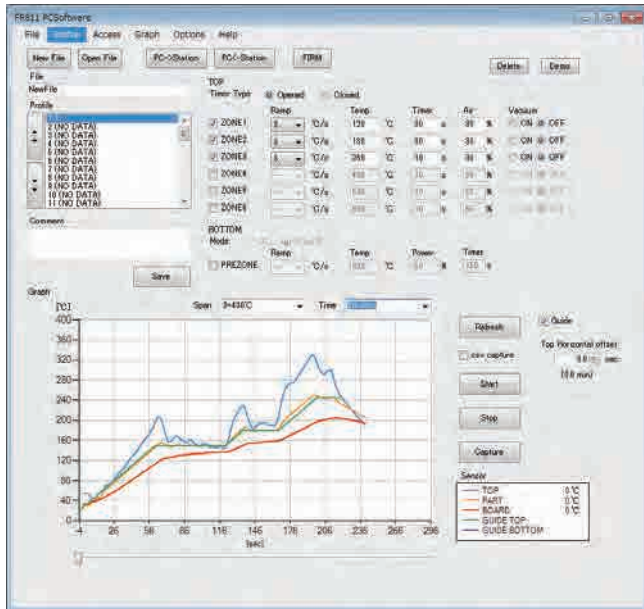

**Linked operation with the bottom heater**

FR-811 can control on/off timing and output of the bottom heater which is available optionally.





# SMD Rework Station

## Common Features of FR-810B and FR-811

### Assembly of a low-cost SMD rework system

A low cost rework system can be assembled with a bottom heater, a grip fixture, and a board holder.  
 \* The following pictures are set-up examples.

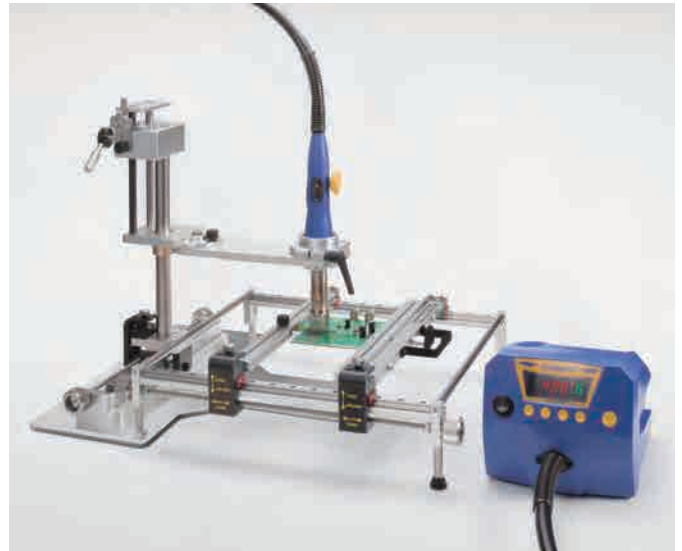
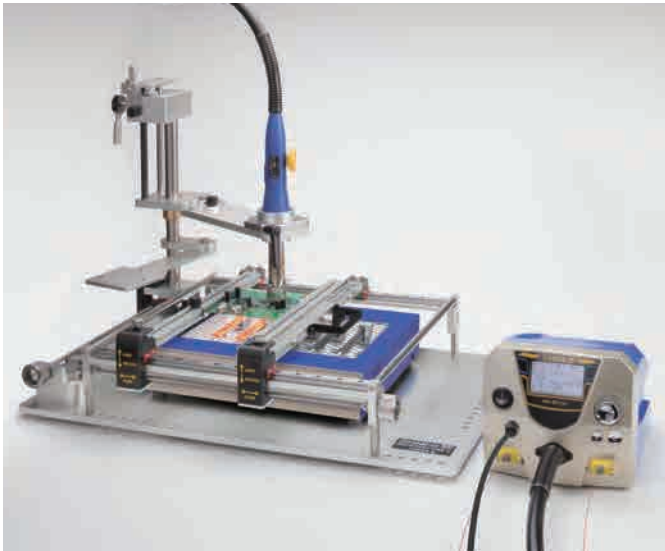

## Option

### Grip Fixture L



A board holder can be easily attached to the large baseplate.

### Grip Fixture M



Recommended if a bottom heater is not required or in case of use of a bottom heater other than the dedicated model for FR-811.

### The dedicated bottom heater for FR-811



Equipped with carbon heaters. Heating area is divided into 2 sections.

### Board Holder



Makes it easy to set and remove a P.W.B. and to make fine adjustments after setting.

### Board Clip



Accepts even irregular-shaped P.W.B.

### Board Support Unit

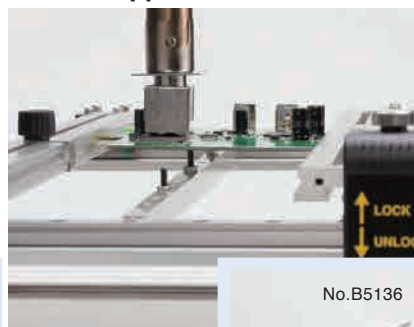

Supports P.W.B. from underneath to minimize its warping.



**Optional Nozzles (Quick-change type) for FR-810B, FR-811 and FR-702**

Unit: mm

Single	N51-01* Single 2.5	N51-02 Single 4	N51-03 Single 5.5	N51-04 Single 7	N51-05* Bent Single 1.5 × 3
BGA	N51-10 BGA 4 × 4	N51-11 BGA 6 × 6	N51-12 BGA 8 × 8	N51-13 BGA 10 × 10	N51-14 BGA 12 × 12
	N51-15 BGA 14 × 14	N51-16 BGA 15 × 15	N51-17 BGA 17 × 17	N51-18 BGA 18 × 18	N51-19 BGA 20 × 20
	N51-20 BGA 22 × 22	N51-21 BGA 24 × 24	N51-22 BGA 27 × 27	N51-23 BGA 29 × 29	N51-24 BGA 35 × 35
	N51-25 BGA 38 × 38	N51-26 BGA 40 × 40			

\* The vacuum function does not operate with these nozzles.

Single nozzle set (N51-01, N51-03, N51-04, and N51-05) is also available.

\* N51-02 included with FR-810B



# SMD Rework Station





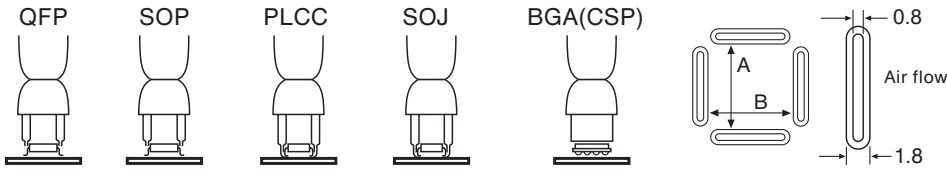









## Optional Nozzles (Conventional type) for FR-810B, FR-811 and FR-702

Unit: mm













The size in each description indicates the size of the package.









### QFP and BQFP

<b>A1125B QFP 10 × 10</b>  A: 10.2 B: 10.2	<b>A1262B QFP 12 × 12</b>  A: 12.2 B: 12.2	<b>A1126B QFP 14 × 14</b>  A: 15.2 B: 15.2	<b>A1128B QFP 14 × 20</b>  A: 15.2 B: 21.2	<b>A1127B QFP 17.5 × 17.5</b>  A: 19.2 B: 19.2
<b>A1261B QFP 20 × 20</b>  A: 20.2 B: 20.2	<b>A1129B QFP 28 × 28</b>  A: 29.7 B: 29.7	<b>A1263B QFP 28 × 40</b>  A: 27.7 B: 39.7	<b>A1265B QFP 32 × 32</b>  A: 32.2 B: 32.2	<b>A1203B QFP 35 × 35</b>  A: 35.2 B: 35.2
<b>A1264B QFP 40 × 40</b>  A: 40.2 B: 40.2	<b>A1215B QFP 42.5 × 42.5</b>  A: 42.5 B: 42.5	<b>A1180B BQFP 17 × 17</b>  A: 18.2 B: 18.2	<b>A1181B BQFP 19 × 19</b>  A: 19.2 B: 19.2	<b>A1182B BQFP 24 × 24</b>  A: 24.2 B: 24.2



### SOP and TSOL

<b>A1131* SOP 4.4 × 10</b>  4.8	<b>A1132* SOP 5.6 × 13</b>  5.7	<b>A1133* SOP 7.5 × 15</b>  7.2	<b>A1134* SOP 7.5 × 18</b>  7.2	<b>A1258B SOP 7.6 × 12.7</b>  8.2
<b>A1260B SOP 8.6 × 18</b>  8.7	<b>A1257B SOP 11 × 21</b>  11.7	<b>A1259B SOP 13 × 28</b>  13.5	<b>A1185B TSOL 13 × 10</b>  11.9	<b>A1186B TSOL 18 × 10</b>  18.2
<b>A1187B TSOL 18.5 × 8</b>  18.5				





### PLCC

<b>A1188B PLCC 9 × 9 (20 pins)</b>  A: 11 B: 11	<b>A1140B PLCC 11.5 × 11.5 (28 pins)</b>  A: 13 B: 13	<b>A1141B PLCC 11.5 × 14 (32 pins)</b>  A: 15 B: 13	<b>A1139B PLCC 12.5 × 7.3 (18 pins)</b>  A: 9 B: 14	<b>A1135B PLCC 17.5 × 17.5 (44 pins)</b>  A: 18.5 B: 18.5
<b>A1136B PLCC 20 × 20 (52 pins)</b>  A: 21 B: 21	<b>A1137B PLCC 25 × 25 (68 pins)</b>  A: 26 B: 26	<b>A1138B PLCC 30 × 30 (84 pins)</b>  A: 31 B: 31	<b>A1189B PLCC 34 × 34 (100 pins)</b>  A: 36.5 B: 36.5	



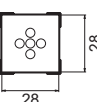
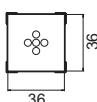
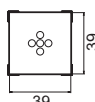
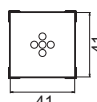

SOJ

<p><b>A1214B SOJ 10 × 26</b></p> 	<p><b>A1183* SOJ 15 × 8</b></p> 	<p><b>A1184B SOJ 18 × 8</b></p> 
--	---	---

BGA

<p><b>A1470 BGA 8 × 8</b></p> 	<p><b>A1471 BGA 12 × 12</b></p> 	<p><b>A1472 BGA 13 × 13</b></p> 	<p><b>A1473 BGA 15 × 15</b></p> 	<p><b>A1474 BGA 18 × 18</b></p> 
<p><b>A1475 BGA 27 × 27</b></p> 	<p><b>A1476 BGA 35 × 35</b></p> 	<p><b>A1477 BGA 38 × 38</b></p> 	<p><b>A1478 BGA 40 × 40</b></p> 	

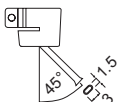
Single

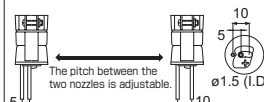
<p><b>A1124B* Single 2.5</b></p> 	<p><b>A1130* Single 4.4</b></p> 	<p><b>A1142B* Bent single 1.5 × 3</b></p> 	<p><b>A1190* Dual single 2.5 × 9.5</b></p> 	<p><b>A1325* Dual single ø1.5 × 5 to 10 Adjustable pitch</b></p> 
--	---	--	--	---

SIP

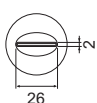
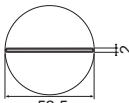
<p><b>A1191* SIP 25L</b></p> 	<p><b>A1192* SIP 50L</b></p> 
--	--

\* The vacuum function does not operate with these nozzles.

## HAKKO FR-701 ESD SAFE REPAIR SYSTEM

Repair System **Digital**



- All-in-one repair system that enables both soldering and desoldering

### Features

For information on features of soldering iron, see P. 17.  
For information on features of desoldering tool, see P. 67.

**NOTE:** Auto Shutoff Function and Auto Sleep Function are available for desoldering tool only.

### Packing List

<b>FR-701</b>	Station, Soldering iron (FX-8801), Desoldering tool (FR-4101), Iron holder for soldering iron (with cleaning sponge and wire), Iron holder for desoldering tool (with cleaning wire), Tool box (Cleaning pin for $\phi 1$ mm, Cleaning pin for heating element, Cleaning drill for $\phi 1$ mm, Nozzle wrench, Filter [qty 2], Ceramic paper filter L [qty 4]), Power cord, Instruction manual
---------------	--

### Replacement Tips and Nozzles

For information on optional irons and replacement tips, see P. 19 to 21.  
For information on replacement nozzles for desoldering tool, see P. 68.

### Specifications

Part No.	FR-701
Power consumption	260 W

#### Station (Soldering iron)

Output voltage	AC 26 V
Temperature range	50 to 480°C
Temperature stability	$\pm 1^\circ\text{C}$ at idle temperature (when set to 200 to 480°C)

#### Station (Desoldering tool)

Output voltage	AC 24 V
Vacuum generator	Vacuum pump, double cylinder type
Vacuum pressure	80 kPa (600 mmHg, max.)
Suction flow	15 L/min.
Temperature range	330 to 450°C
Temperature stability	$\pm 5^\circ\text{C}$ at idle temperature

#### Station

Dimensions	190 (W) $\times$ 140 (H) $\times$ 220 (D) mm
Weight	6.2 kg

#### Soldering iron

Power consumption	65 W (26 V)
Tip to ground resistance	$< 2 \Omega$
Tip to ground potential	$< 2$ mV
Heating element	Ceramic heater
Standard tip	Shape-B (No. T18-B)
Cord length	1.2 m
Total length*	217 mm (with B tip)
Weight*	46 g (with B tip)

#### Desoldering tool

Power consumption	140 W (24 V)
Nozzle to ground resistance	$< 2 \Omega$
Nozzle to ground potential	$< 2$ mV
Heating element	Composite heater
Standard nozzle	$\phi 1$ mm S type (No. N61-05)
Cord length	1.2 m
Total length**	168 mm (with $\phi 1$ mm S type nozzle)
Weight**	170 g (with $\phi 1$ mm S type nozzle)

\* Without cord

\*\* Without cord and hose

## HAKKO FR-702 ESD SAFE REWORK SYSTEM

### Rework System Digital



- Multi-station that enables soldering, desoldering, and SMD rework all with a single unit

### Features

For information on features of soldering iron, see P. 17.  
 For information on features of desoldering tool, see P. 67.  
 For information on features of hot air, see P. 73 to 74 (common features).  
**NOTE:** Auto Shutoff Function and Auto Sleep Function are available for desoldering tool and hot air only.  
 Low Temperature Error Alert is available for soldering iron and desoldering tool only.

### Packing List

<b>FR-702</b>	Station with hot air handpiece, Nozzle (ø4 mm) for hot air, Handpiece holder for hot air, Vacuum pipe control knob L (with screw), Pads (qty 2 each of ø3 mm, ø5 mm, ø7.6 mm), Soldering iron (FX-8801), Desoldering tool (FR-4101), Iron holder for soldering iron (with cleaning sponge and wire), Iron holder for desoldering tool (with cleaning wire), Tool box (Cleaning pin for ø1 mm, Cleaning pin for heating element, Cleaning drill for ø1 mm, Nozzle wrench, Filter [qty 2], Ceramic paper filter L [qty 4]), Heat resistant pad, Color band (qty 2), Power cord, Instruction manual
---------------	--

### Replacement Tips and Nozzles

For information on optional irons and replacement tips, see P. 19 to 21.  
 For information on replacement nozzles for desoldering tool, see P. 68.  
 For information on replacement nozzles for hot air, see P. 77 to 79.

### Specifications

Part No.	FR-702
Power consumption	1030 W (100 V), 1170 W (110 V), 1430 W (220 V), 1530 W (230 V), 1630 W (240 V)

#### Station (Soldering iron)

Output voltage	AC 26 V
Temperature range	50 to 480°C
Temperature stability	±1°C at idle temperature (when set to 200 to 480°C)

#### Station (Desoldering tool)

Output voltage	AC 24 V
Vacuum generator	Vacuum pump, double cylinder type
Vacuum pressure	80 kPa (600 mmHg, max.)
Suction flow	15 L/min.
Temperature range	330 to 450°C
Temperature stability	±5°C at idle temperature

#### Station (SMD rework station)

Power consumption	30 W
Air flow*	1 to 9 (5 to 115 L/min.)
Temperature range	50 to 600°C

#### Station

Dimensions	370 (W) × 150 (H) × 220 (D) mm
Weight	9 kg

#### Soldering Iron

Power consumption	65 W (26 V)
Tip to ground resistance	<2 Ω
Tip to ground potential	<2 mV
Heating element	Ceramic heater
Standard tip	Shape-B (Part No. T18-B)
Cord length	1.2 m
Total length**	217 mm (with B tip)
Weight**	46 g (with B tip)

#### Desoldering tool

Power consumption	140 W (24 V)
Nozzle to ground resistance	<2 Ω
Nozzle to ground potential	<2 mV
Heating element	Composite heater
Standard nozzle	ø1 mm S type (No. N61-05)
Cord length	1.2 m
Total length***	168 mm (with ø1 mm S type nozzle)
Weight***	170 g (with ø1 mm S type nozzle)

#### Handpiece (Hot air)

Power consumption	670 W (100 V), 810 W (110 V), 1070 W (220 V), 1170 W (230 V), 1270 W (240 V)
Standard nozzle	ø4 mm (No. N51-02)
Total length**	250 mm
Weight**	180 g

\* Air flow capacity is rated as free flowing. Restrictions created by various nozzles may reduce the maximum airflow capacity.

\*\* Without cord.

\*\*\* Without cord and hose.



# Preheater

## HAJKO FR-870B PREHEATER ESD SAFE

IR Preheater Digital



- Infrared preheater that provides the optimal heating effect over the whole workpiece surface
- Non-contact system enables the application of this preheater to doublesided boards.
- 2 independent switchable work grid partitions

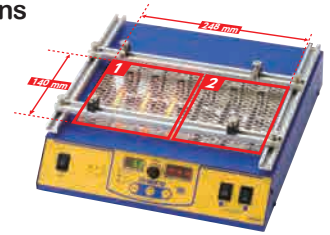

## HAJKO FR-872 PREHEATER ESD SAFE

Large Size IR Preheater Digital



- Large heating area 286 (W) x 350 (D) mm
- 4 independent switchable work grid partitions

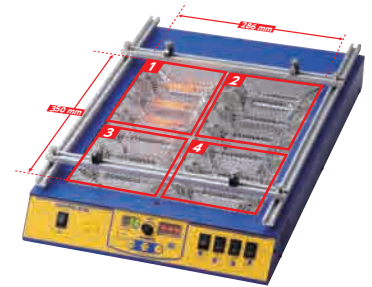

## HAJKO FR-830 PREHEATER ESD SAFE

Preheater Analog



- Compact pre-heater best suited for heat processing on localized areas
- Featuring quick heatup and less variations in temperature



### Features of FR-870B and FR-872

#### Power Mode

Control heater out put from 0% to 100%.

#### T/C Mode

Sense the temperature of the sensor attached to the board and control to maintain the set temperature for the board.



#### Auto Mode

Auto mode provides three steps (step 1 to 3) to create an optimal heating profile for the workpiece.

#### With Power Mode

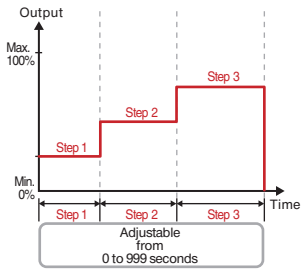

#### With T/C Mode

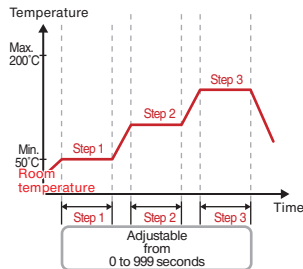

### Features of FR-830

#### Preheating in a short time

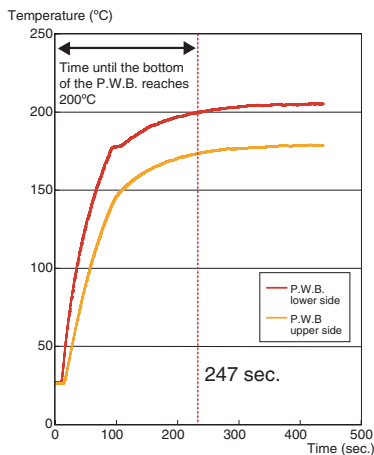

#### Test criteria

Measurement method	Temperature measured using sensors mounted on both the top and bottom surfaces of the P.W.B.
Distance between air outlet and P.W.B.	10 mm
Temperature setting	300°C

### Packing List

FR-870B	Unit, Thermocouple, Power cord, Heater lamp, Instruction manual
FR-872	Unit, Thermocouple, Heater, Power cord, Instruction manual

### Specifications

Model No.	FR-870B	FR-872
Power consumption	500 W (100 V) 610 W (110 V) 730 W (120 V) 1130 W (220 V) 1240 W (230 V)	1050 W (100 V) 1250 W (110 V) 1440 W (120 V) 1150 W (220 V) 1250 W (230 V)
Operation mode	Power mode, T/C mode Auto power mode, Auto T/C mode	
Setting range	Power mode: 0 to 100% T/C mode: 50 to 200°C Set time: 0 to 999 seconds	
Heating element	Carbon heater	High efficiency carbon heater
Heater area dimensions	248 (W) × 140 (D) mm	286 (W) × 350 (D) mm
Heater zone	2	4
Temperature sensor	K-type thermocouple	
Heater lamp lifetime*	2100 hours	2100 hours
Heater control	Power mode: Percentage-based system T/C mode: PID control	
External connections	Start signal input possible	
Dimensions	290 (W) × 100 (H) × 311 (D) mm	AC100 to 120 V: 360 (W) × 97 (H) × 535 (D) mm AC220 to 230 V: 360 (W) × 97 (H) × 524 (D) mm
Weight	3.2 kg	5.6 kg

\* Provided for reference purpose only and is not guaranteed.

### Packing List

FR-830	Unit, Power cord, Instruction manual
--------	--------------------------------------

### Specifications

Model No.	FR-830
Power consumption	210 W (100 V), 240 W (110 V), 470 W (120 V), 230 W (220 V), 250 W (230 V), 270 W (240 V)
Air flow	0.15 m <sup>3</sup> /min. (fan capability)
Temperature range	150 to 300°C (above the hot air outlet)
Dimensions*	140 (W) × 75 (H) × 185 (D) mm
Weight	0.75 kg

\* The height (H) is the distance from the bottom of the feet to the top of the exhaust outlet.

### Option

Part No.	Name	Specifications
B3263	Extension pipe	with lid
B2763	Hand switch	-
B1649	Foot switch	-

# Air-Purifying Smoke Absorber

**HAKO** FUME EXTRACTION **FA-430** ESD SAFE

## Air-Purifying Smoke Absorber



- HEPA filter (High Efficiency Particulate Air Filter)
- Filters out 99.97% of particles greater than 0.3  $\mu\text{m}$
- Recommended for quiet laboratory and office

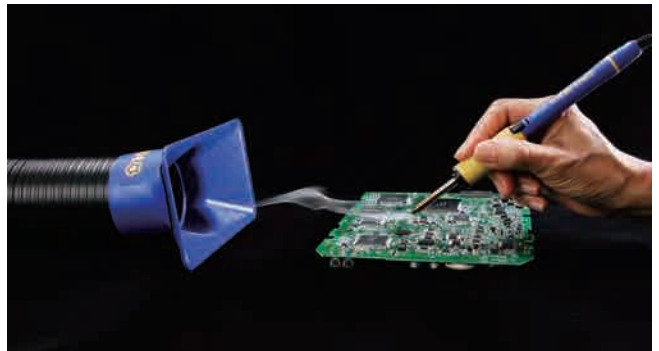

### Features of FA-430

Filter efficiency is 99.97% of particles greater than 0.3  $\mu\text{m}$  (HEPA filter).

Aerosol particle diameter range

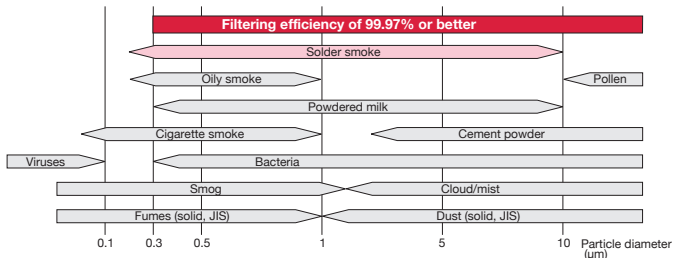

**NOTE:** Filter efficiency is an initial value of collection efficiency based on counting method for airborne dust collected by a single plate of filter (unfolded).

### Packing List

<b>FA-430</b>	Main unit, Power cord, Cap, Main filter, Pre-filter (qty 10), Instruction manual
---------------	--

\* Ducts are optional parts.

### Filter replacement notification function

#### Pre-filter

When the pre-filter is 80% clogged or has been used for 200 hours, the orange indicator flashes on and off.

#### HEPA main filter

When the 10th pre-filter needs replacing, the orange and red lamps flash on and off.

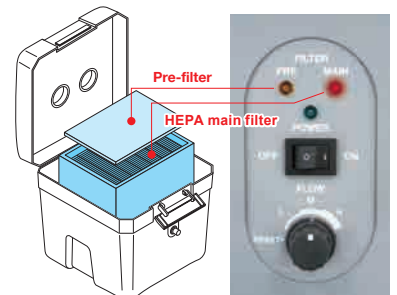

### Specifications

Model No.	FA-430	
Power consumption	110 W	
Noise level*	50 dB (A) (MEDIUM mode)	
Suction capacity**	HIGH	4.7 m <sup>3</sup> /min.
	MEDIUM	3.7 m <sup>3</sup> /min.
	LOW	2.8 m <sup>3</sup> /min.
Filtering efficiency	HIGH	99.96% (0.3 $\mu\text{m}$ )***
	MEDIUM	99.97% (0.3 $\mu\text{m}$ )***
	LOW	
Static pressure	1500 Pa	
Duct set (sold separately)****	$\phi$ 55 mm $\times$ 1.2 m (ESD SAFE)	
Dimensions	330 (W) $\times$ 366 (H) $\times$ 343 (D) mm	
Weight	7.5 kg	

\* Measured at a distance of 1 meter from the face of the unit in an anechoic chamber.

\*\* When using two ducts

\*\*\* It is an initial value of collection efficiency based on counting method for airborne dust collected by a single plate of filter (unfolded).

\*\*\*\* Nets in duct sets are not protected against electrostatic discharge.

# HAKO FA-431 ESD SAFE

## Air-Purifying Smoke Absorber



- Excellent cost performance filter
- Filters out 97% of particles greater than 0.3  $\mu\text{m}$
- Optional sub-filters extend the life of Pre and Main filters
- Ideal for factories with a lot of soldering work

### Features of FA-431

The life of pre-filter and main filter will be approximately 4 times\* longer.

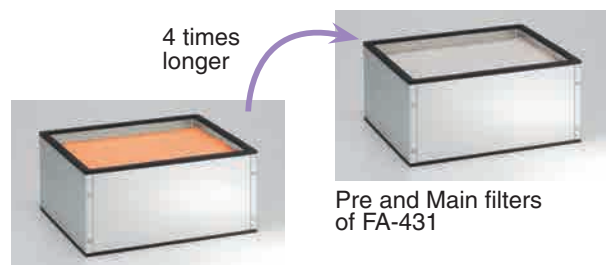

Pre and Main filters of FA-430

Pre and Main filters of FA-431

With the use of sub-filter, it will be approximately 10 times\* longer.

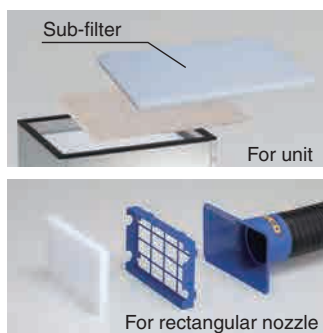

Remote control equipped  
Very easy to switch ON/OFF



\* The filter life will be differ depending on the work environments and work conditions.

### Packing List

FA-431	Main unit, Power cord, Remote control, Cap, Main filter, Pre-filter (qty 10), Instruction manual
--------	--

\* Ducts are optional parts.

### Specifications

Model No.		FA-431
Power consumption		110 W
Noise level*		50 dB (A) (MEDIUM mode)
Suction capacity**	HIGH	4.7 m <sup>3</sup> /min.
	MEDIUM	3.7 m <sup>3</sup> /min.
	LOW	2.8 m <sup>3</sup> /min.
Filtering efficiency	HIGH	97% ( $\geq 0.3 \mu\text{m}$ )
	MEDIUM	
	LOW	
Static pressure		1500 Pa
Duct set (sold separately)***		$\varnothing 55 \text{ mm} \times 1.2 \text{ m}$ (ESD SAFE)
Dimensions		330 (W) $\times$ 366 (H) $\times$ 343 (D) mm
Weight		7.2 kg

\* Measured at a distance of 1 meter from the face of the unit in an anechoic chamber.

\*\* When using two ducts

\*\*\* Nets in duct sets are not protected against electrostatic discharge.



# Air-Purifying Smoke Absorber

## Common Features of FA-430 and FA-431

### Quiet operation and powerful suction

	FA-430/431		Previous model (HAKKO 421)	
	Noise level dB (A)	Air volume m <sup>3</sup> /min.	Noise level dB (A)	Air volume m <sup>3</sup> /min.
HIGH	53	4.7	60*	3.2*
MEDIUM	50	3.7		
LOW	44	2.8		

\*Values measured when the unit was used with a 60 Hz power supply.

### Flexible ducts and compact body for perfect placement



### Movement of smoke is affected by the surrounding environment

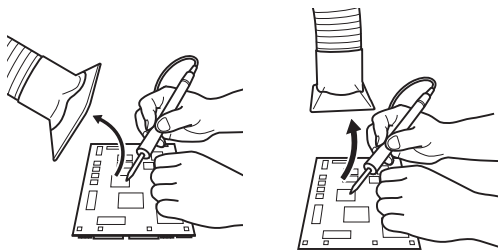

If the duct is mounted at an angle above the workpiece, it is affected by air conditioning.

If the duct is mounted directly above, it can be difficult to see the workpiece.

### Recommended angle

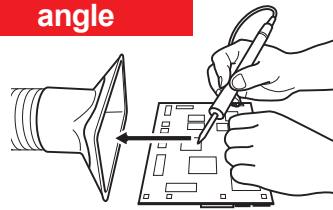

Duct is mounted on the worktable to provide excellent suction performance.

### Freestanding ducts



Perfect placement provides suction where you need it.

### Option

Part No.	Name	Specifications
C1571	Duct Set	With rectangular nozzle
C1572	Duct Set	With round nozzle
A5035	Sub-filter	For FA-431, set of 5
A5036	Sub-filter for rectangular nozzle	For FA-431, set of 20
A5037	Sub-filter for round nozzle	For FA-431, set of 20
B5146	Filter case for rectangular nozzle	For FA-431
B5147	Filter case for round nozzle	For FA-431



No.C1571



No.C1572



1: No.A5035

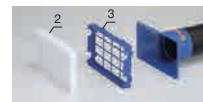

2: No.A5036  
3: No.B5146



4: No.A5037  
5: No.B5147



# Desktop Type Smoke Absorber

## HAKKO FA-400 SMOKE ABSORBER ESD SAFE

### Desktop Type Smoke Absorber



- Desktop solder smoke absorber that can be mounted horizontally or vertically
- An optional arm stand makes a third mounting position available.

#### 2 Way Plus Placement

##### Vertically mounted:



##### Horizontally mounted:



##### Using a stand (option):



#### Packing List

FA-400	Unit, Filter, Instruction manual
--------	----------------------------------

#### Specifications

Model No.	FA-400
Power consumption	50 Hz: 15 W (100 V), 18 W (110 V), 19 W (220 V), 22 W (230 V), 24 W (240 V) 60 Hz: 13 W (100 V), 15 W (110 V), 19 W (120 V), 16 W (220 V), 18 W (230 V), 19 W (240 V)
Noise level*	50 Hz: 48 dB 60 Hz: 51 dB
Suction capacity**	Vertically: 1 m <sup>3</sup> /min. (50 Hz), 1.1 m <sup>3</sup> /min. (60 Hz) (max.) Horizontally: 0.4 m <sup>3</sup> /min. (50 Hz), 0.5 m <sup>3</sup> /min. (60 Hz) (max.)
Air velocity	Vertically: 1 m/sec. (50 Hz), 1.1 m/sec. (60 Hz) Horizontally: 2.6 m/sec. (50 Hz), 2.9 m/sec. (60 Hz)
Filter size	130 (W) × 130 (H) × 10 (D) mm
Dimensions	166 (W) × 212 (H) × 113 (D) mm
Weight***	0.91 kg

\* Measured at a distance of 1 m from the face of the unit

\*\* Measured with a filter present

\*\*\* Without cord

#### Option

Part No.	Name	Specifications
C1568	Arm stand	With knobs

# Desktop Type Smoke Absorber

## HAKKO 490 SMOKE CLEANER

### External Air Compressor Type Smoke Absorber



- External air compressor type soldering smoke absorber
- Three inner filters attached on different levels absorb soldering smoke.
- Up to 2 soldering irons can be connected to one unit.

### Compatible Soldering Station for HAKKO 490



FX-801



FX-100



FX-888D



FX-889



FX-951



FX-950



FX-838



FM-203



FM-206



DASH

### Specifications

Model No.	490
Noise level	39 dB
Working pressure	392 to 686 kPa (4 to 7 kgf/cm <sup>2</sup> )
Air consumption	40 L/min. (490 kPa)
Suction flow	23 L/min. (490 kPa)
Dimensions	ø120 × 200 (H) mm
Weight*	1.5 kg

\* Unit only

\*\* Use compressed air; no power supply is necessary.

### Packing List

490	Unit, Absorption pipe set, Instruction manual
-----	---

\* A second soldering iron can be attached to HAKKO 490 by purchasing an additional absorption pipe set.

## HAKKO 494 SMOKE ABSORBER

### Smoke Absorbing System



- Soldering smoke absorber for production-line use that enables the exhausting of fumes to an outdoor location
- Equipped with a suppressor to reduce exhaust noise during operation
- Up to 10 soldering irons can be connected to one unit

#### Example of Connections

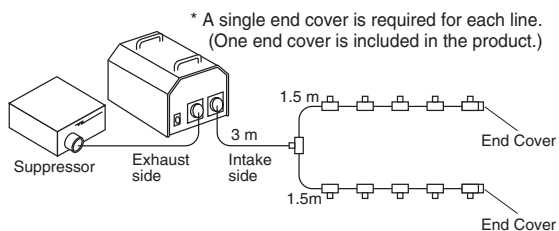

#### Packing List

<b>494</b>	Unit, Filter case, Filter cap, Pre-filter (5 pcs), Duct (3 m), End cover, Main filter (5 pcs), Inlet socket, Exhaust duct (5 m), Nylon strap, Suppressor, Absorption pipe set, Instruction manual
------------	---

\*When ordering HAKKO 494, specify the part number of the absorption pipe set.

#### Option

Part No.	Name	Specifications
C1540	Absorption pipe set <R>	Any with a handle ø16 mm or smaller
B1246	Parallel piping joint	-

#### Specifications

Model No.	494
Power consumption	50 Hz: 150 W 60 Hz: 200 W
Noise level*	With hose: 55 dB Without hose: 71 dB
Suction capacity	50 Hz: 1.56 m <sup>3</sup> /min. 60 Hz: 1.82 m <sup>3</sup> /min.
Static pressure	50 Hz: 2.3 kPa (240 mmAq.) 60 Hz: 3.2 kPa (325 mmAq.)
Dimensions**	322 (W) × 300 (H) × 386 (D) mm
Weight***	18 kg

\* Measured at a distance of 1 m from the face of the unit.

\*\* Without handle and cord

\*\*\* Unit only

## HAKKO FE-510 STATIC ELIMINATOR

### Static Eliminator



- Static eliminator enables the selection of the area in which static will be neutralized.
- Locking mechanism maintains the angle of the eliminator unit.
- Error output signal function is useful when incorporating the unit into line applications.

### Features

#### Static elimination area

##### Wide-angle louver

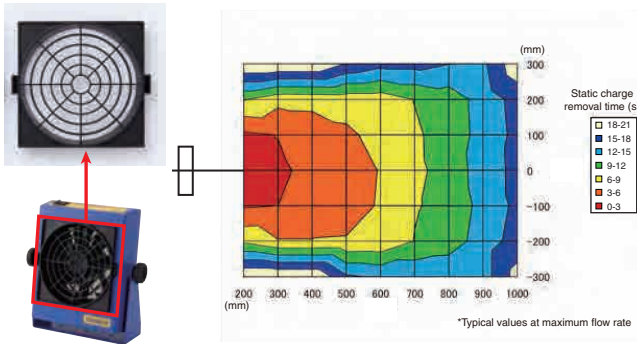

##### Straight louver

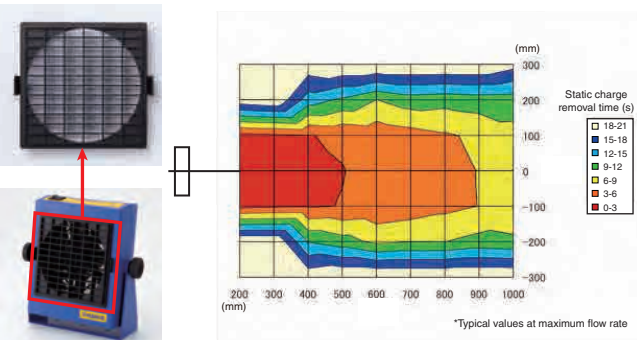

#### Error output signal

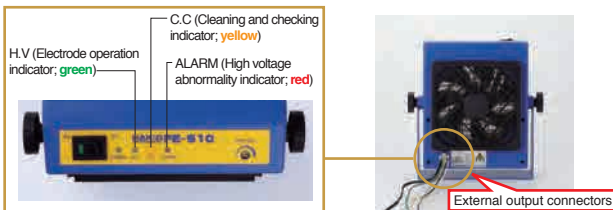

#### Superb ease of maintenance

The discharge electrode can be replaced simply by turning it gently in the clockwise direction.



### Packing List

FE-510	Unit (with wide-angle louver), Straight louver, Cleaning brush, Filter, AC adapter, Output signal connection lead (1 set), Instruction manual
--------	---

### Specifications

Model No.	FE-510
AC adapter output/Capacity	DC 24 V 10 VA
Discharge method	High frequency AC method
High voltage output	Approx. AC 2000 V
Ion balance*	±10 V or less
Static elimination time*	Straight louver: Approx. 1.5 sec. Wide-angle louver: Approx. 2.5 sec.
High voltage abnormality output (ALARM)	MOS FET relay output Maximum allowed current: 100 mA Applied voltage: DC 30 V or less
Cleaning check output (C.C)	MOS FET relay output Maximum allowed current: 100 mA Applied voltage: DC 30 V or less
Air flow	1.5 to 3 m <sup>3</sup> /min.
Air flow out angle	Vertically 360° variable (every 10°)
Quantity of produced ozone**	0.04 ppm or less
Operating environment	Ambient temperature: 0 to 40°C Ambient humidity: 15 to 65% (without condensation)
Material for discharge electrode	Tungsten
Dimensions	150 (W) × 182 (H) × 50 (D) mm (without stand)
Weight***	0.79 kg

#### AC adapter

AC adapter output/Capacity	DC 24 V 1 A
Dimensions	34 (W) × 72 (H) × 51 (D) mm
Weight	100 g

\* Typical value measured (before shipment) at a distance of 300 mm from the center of the fan outlet with the maximum flow rate

\*\* Measured at a point 150 mm away from the center of the fan outlet

\*\*\* Including stand



# Wrist Strap

## HAKKO 442B

WRIST STRAP

### Wrist Strap



- This antistatic wrist strap prevents the human body from becoming charged with static electricity.
- The stretchable band is easy to adjust.
- A conductive thread is used for the band lining.

### Cord Helper

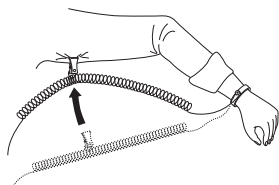

1. Insert the grounding wire into the ring of the cord helper.
2. Clip the cord helper to clothing as shown here.

### Packing List

442B	Wrist band, Grounding wire, Cord helper, Instruction manual
------	---

### Specifications

Part No.	442B-01	442B-02	442B-04	442B-05	442B-06	442B-07
Color	Blue		Light green		Gray	
Grounding wire	1.5 m	2.5 m	1.5 m	2.5 m	1.5 m	2.5 m

# Wrist Strap Tester

## HAKKO 498

SYSTEM TESTER

### Wrist Strap Tester



- Easy-to-use, quick-response tester for wrist straps

### Packing List

498	Unit, 006P 9 V Manganese dry battery (for trial), Grounding wire, Instruction manual
-----	--

### Features

Can be used anywhere to quickly and easily check a variety of grounding systems.



### Specifications

Model No.	498
Power supply	006P 9 V dry battery
Indication: LOW	$R < 800 \text{ k}\Omega$
Indication: GOOD	$800 \text{ k}\Omega \leq R \leq 9 \text{ M}\Omega$
Indication: HIGH	$R > 9 \text{ M}\Omega$
Battery life	Approx. 50,000 times
Grounding wire	2.5 m
Operating environment	0 to 40°C, 20 to 90%RH (without condensation)
Dimensions	80 (W) × 40 (H) × 117 (D) mm
Weight*	110 g

\* Without battery



## HAKKO FG-460 FOOTWEAR TESTER

### Footwear Tester

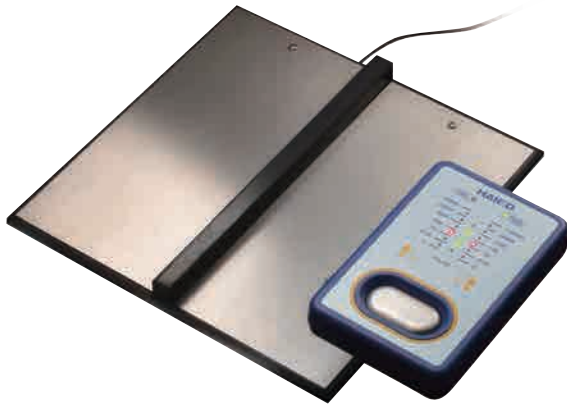

- Very easy-to-use footwear tester
- Information of measurement and evaluation of electrical resistance at a glance
- Meet the criteria of standards such as JIS T 8103:2010 and ANSI/ESD S20.20

### Features

#### Individual measurement

Measure the anti-static performance of shoes individually. Prevents faulty measurement with the divider on test plate.

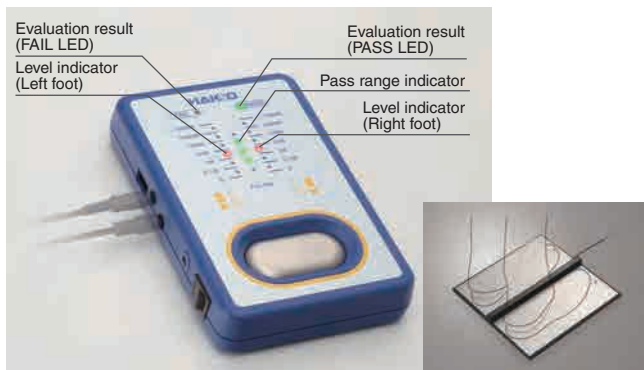

#### Evaluation external output

Side view



External output terminal

Example of interlock



#### Optional Stand (C5032)



### Packing List

<b>FG-460</b>	Unit, Mounting base, AC adapter*, Test plate, Mounting screw (qty 2)**, Pan head screw (qty 2), Wood screw (qty 2), Instruction manual
---------------	--

\* AC adapter may not be included depending on the specifications.

\*\* Delivered as they are screwed onto the unit.

NOTE: Stand (C5032) is sold separately.

### Specifications

Model No.		FG-460
Rating		DC 24 V 33 mA
Measurement voltage		DC 20 V
Measurement range	Upper evaluation limit	1000 M $\Omega$ (1 $\times$ 10 <sup>9</sup> $\Omega$ ) 100 M $\Omega$ (1 $\times$ 10 <sup>8</sup> $\Omega$ ) 10 M $\Omega$ (1 $\times$ 10 <sup>7</sup> $\Omega$ )
	Lower evaluation limit	1 M $\Omega$ (1 $\times$ 10 <sup>6</sup> $\Omega$ ) 0.1 M $\Omega$ (1 $\times$ 10 <sup>5</sup> $\Omega$ ) R < 0.1 M $\Omega$ (1 $\times$ 10 <sup>5</sup> $\Omega$ )
	Conductivity evaluation	R < 0.1 M $\Omega$ (1 $\times$ 10 <sup>5</sup> $\Omega$ )
Evaluation level accuracy	R < 0.1 M $\Omega$	$\pm$ 5%
	0.1 M $\Omega$ $\leq$ R $\leq$ 100 M $\Omega$	$\pm$ 10%
	100 M $\Omega$ < R	$\pm$ 8%
Operating environment		Ambient temperature / humidity range 0 to 40°C, 20 to 90%RH (without condensation)
Environment condition		Applicable rated pollution degree 2 (According to IEC / UL61010-1)
Dimensions		120 (W) $\times$ 30 (H) $\times$ 185 (D) mm
Weight*		0.55 kg

#### Test plate

Cord length	1.6 m
Dimensions**	300 (W) $\times$ 30 (H) $\times$ 300 (D) mm
Weight**	1.9 kg

#### AC adapter

Output voltage	DC 24 V
----------------	---------

\* Including mounting base

\*\* Without cord

### Option

Part No.	Name
C5032	Stand

## HAKKO FG-450 STATIC LEVEL METER

### Static Level Meter



- Portable static level meter for the measurement of electric potential of films and plastic objects
- Useful when checking electric potential measurements in production lines.
- Also suitable for performing operation test of static eliminators.

### Features

#### Rotating sensor head

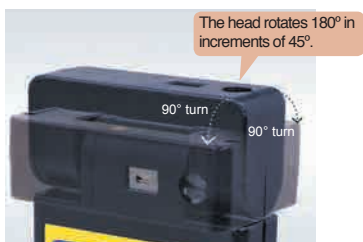

#### Selectable two modes in measurement

- Measuring static electricity (resolution: 10 V)



The red light image is projected to a point about 30 mm from the meter.



- Measuring ion balance (resolution: 1 V)



### Packing List

FG-450	Unit (with carrying case), Grounding wire, Strap, 006P 9 V Manganese dry battery (for trial), Ion balance plate (with screw), Instruction manual
--------	--

### Specifications

Model No.	FG-450
Power supply	006P 9 V dry battery
Measurable potential range	Normal mode: 0.00 to $\pm 19.99$ kV (resolution: 0.01 kV) Ion balance mode: 0.000 to $\pm 1.999$ kV (resolution: 0.001 kV)
Signal detection method	Oscillating chopper method
Display refresh frequency	0.5 seconds
Measurement precision	$\pm 10\%$ of reading $\pm 2$ digits
Continuous operating limit	Approx. 10 hours (with an alkaline battery)
Measurement distance	30 mm (between object being measured and sensor)
Measurement distance adjustment	Red LED beam focusing method
Sensor head rotation angle	180° (stops every 45°)
Display	LCD display with built-in backlight
Polarity display	Positive polarity/negative polarity display
Mode switching	Switch modes by pressing MODE button
Battery check	Remaining charge displayed in display panel
Operating environment	0 to 40°C, 20 to 70%RH (without condensation)
Dimensions	68 (W) $\times$ 138 (H) $\times$ 22 (D) mm
Weight*	160 g

\* Including battery

### Option

Part No.	Name	Specifications
B3586	Body changing level measurement plate	-

## HAKKO FG-102 THERMOMETER

### Soldering Iron Thermometer with Traceability Management System



- Free of errors in temperature measurement
- Free of transcription errors for measured temperature
- Standardization of temperature measurement
- Secure management of tip temperature records

#### Packing List

<b>FG-102</b>	Unit, Battery (6 pcs, for trial), Barcode reader, USB cable, Software (CD-ROM), Sensor (10 pcs), Barcode sticker for soldering iron ID (30 pcs), Barcode sticker for operator ID (30 pcs), Instruction manual
---------------	---

#### Option / Replacements

Part No.	Name	Specifications
A1310	Temperature probe	for soldering bath & pot
C1541	Temperature probe	for hot air
A1556	Sensor A	—
A1557	Sensor B	—
C5009	Bar code reader	—
191-212	Sensor	lead-free, set of 10

#### Specifications

Model No.	FG-102
Power supply	AA sized (LR6) battery × 6 (alkaline cell recommended)
Temperature resolution	1°C
Temperature measurement range	0 to 700°C
Temperature precision	±3°C (300 to 600°C) ±5°C (other than above)
Temperature sensor*	K (CA) type thermocouple
Display	LCD
Operating environment	0 to 40°C, 20 to 90%RH (without condensation)
Environmental conditions	Applicable rated pollution degree 2 (according to IEC/UL 61010-1)
Dimensions**	193 (W) × 90 (H) × 219 (D) mm
Weight***	0.93 kg

\* Temperature sensor (No.191-212 or No.191-212C) can only be used if measure temperatures below 500°C. To measure higher temperatures, use an applicable temperature probe.

\*\* Without barcode reader

\*\*\* Without battery and barcode reader

\*\*\*\* Traceability management function can only be used for soldering irons.

## Features

### An Innovation in Tip Temperature Control

#### Flow chart of management



1. Scan the unit and the measurer's ID by a barcode reader.
2. Measure the temperature.
3. Press the REC button to save the data on the unit main body.
4. Transfer and save the data on the PC.

#### Free of errors in temperature measurement by standardization of temperature measurement

The unit has a function to notify the end of measurement. When measurement is finished, "H" icon stops blinking. The unit can find measurement errors and prompt an operator to repeat measurement. The display shows "Fail" if tip loses appropriate contact with sensor before completion of measurement.

#### Pass/Fail judgment on measured temperature

Pass/Fail judgment on measured temperature can be automatically made if an acceptable temperature range is registered in advance (the display shows "OK" or "Fail").

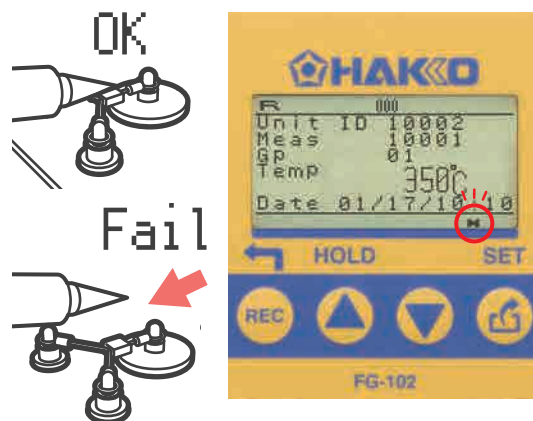

#### Make it easy to manage tip temperature records by transferring the data to computer



No	InstID	Gr No	MeasID	Temp	Set Temp	Month	day	hour	min	OK/NG
1	10023	0	10005	375	0	10	21	14	47	---
2	10024	0	10005	372	0	10	22	14	48	---
3	10025	0	10005	372	0	10	23	14	45	---
4	10026	0	10005	373	0	10	24	14	50	---
5	10027	0	10005	375	0	10	25	14	51	---
6	10028	0	10005	375	0	10	26	14	52	---
7	10029	0	10005	373	0	10	27	14	53	---
8	10030	0	10005	376	0	10	28	14	54	---
9	10001	1	10005	371	380	10	29	14	55	OK
10	10002	1	10005	371	380	10	30	14	55	OK
11	10003	1	10005	372	380	10	31	14	56	OK
12	10004	1	10005	382	380	10	32	14	57	OK
13	10005	5	10005	382	380	10	33	15	3	NG
14	10006	5	10005	380	380	10	34	15	4	NG

Free of transcription errors for measured temperature

## More Features



#### Group control

Groups can be created based on different set temperatures for different operations. Pass/Fail judgment on measured temperatures can be automatically made for different acceptable temperature ranges.



Automatic counting of the number of measurements



Notification of the calibration date



## HAKKO FG-100

THERMOMETER

### Soldering Iron Thermometer



- Tip thermometer that provides reliable temperature control of soldering iron tips
- Compact design minimizes your workspace and enables you to easily carry it around.
- Incorporating an extremely fine sensor that has high temperature reactivity.

## HAKKO FG-101

SOLDERING TESTER

### Soldering Iron Tester



- Tip temperature, leak voltage, and tip-to-ground resistance can be easily measured with high accuracy.
- Soldering iron tester useful for daily maintenance of station-type soldering irons

#### What is leak voltage and tip-to-ground resistance?

##### Leak voltage

Leak current is the current that leaks from the tip to a board or device. Leak voltage is a specific measurement of the level of this current. The leakage can adversely affect delicate devices, so it is necessary to check leak voltage on a daily basis.



##### Tip-to-ground resistance

Most leak current flows from the tip via the ground wire to the outlet ground terminal, and is prevented from affecting the device. Because of this, tip-to-ground resistance is another important issue that must be checked daily.

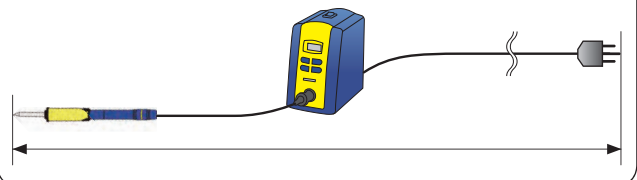



### Common Features of FG-100 and FG-101

#### Dimensional measurement



\*Design image only

#### MAX HOLD function

When the “MAX HOLD” button is pressed, “MAX HOLD” is displayed and the highest tip temperature is held on the display.



### Procedure for Measuring the Soldering Tip Temperature

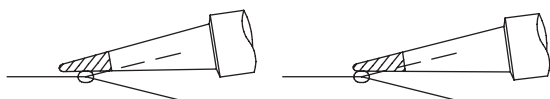

- Typical measuring point for Shape B, I and D (Measure at the center of the tin coated area)

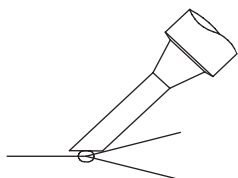

- Typical measuring point for Shape BC and C which are tinned flat only.

### Option / Replacements

Part No.	Name	Specifications
A1310	Temperature probe	For solder bath and pot
C1541	Temperature probe	For hot air
A1556	Sensor A	-
A1557	Sensor B	-
191-212	Sensor/10 pcs	-

### Packing List

FG-100	Unit, 006P 9 V Manganese dry battery (for trial), Instruction manual, Sensor (10 pcs)
FG-101	Unit, Fuse, Conduction wire, Sensor (10 pcs), Multi-adapter, European adapter, Ground clip, Power cord, Instruction manual

\* The Multi-adapter and the European adapter may not be included depending on the type of electrical connection used in your country.

### Specifications

Model No.	FG-100
Power supply	006P 9 V dry battery (alkaline cell recommended)
Temperature resolution	1°C
Temperature measurement range	0 to 700°C
Temperature precision	±3°C (300 to 600°C) ±5°C (other than above)
Temperature sensor*	K (CA) type thermocouple
Display	LCD: 3 1/2 digits
Operating environment	0 to 40°C, 20 to 90%RH (without condensation)
Environmental conditions	Applicable rated pollution degree 2 (according to IEC/UL 61010-1)
Dimensions**	68 (W) × 140 (H) × 38 (D) mm
Weight***	115 g

\* The temperature sensor (No.191-212 or No.191-212C) can only be used to measure temperatures below 500°C. To measure higher temperatures, use an applicable temperature probe.

\*\* Excluding protrusions

\*\*\* Without battery

Model No.	FG-101
Power consumption	2.6 W (100 V), 2.9 W (110 V), 2.6 W (120 V), 2.7 W (220 V), 2.8 W (230 V), 3 W (240 V)
Temperature resolution	1°C
Temperature measurement range	0 to 700°C
Temperature precision	±3°C (300 to 600°C) ±5°C (other than above)
Temperature sensor*	K (CA) type thermocouple
Voltage resolution	0.1 mV
Voltage measurement range	0 to 40 mV (AC)
Voltage precision	± (5% of reading + 1 digit)
Resistance resolution	0.1 Ω
Resistance measurement range	0 to 40 Ω
Resistance precision	± (5% of reading + 1 digit)
Display	LCD: 3 1/2 digits
Operating environment	0 to 40°C, 20 to 90%RH (without condensation)
Environmental conditions	Applicable rated pollution degree 2 (according to IEC/UL 61010-1)
Dimensions	200 (W) × 50 (H) × 120 (D) mm
Weight	1 kg

\* The temperature sensor (No.191-212 or No.191-212C) can only be used to measure temperatures below 500°C. To measure higher temperatures, use an applicable temperature probe.

## HAKO FV-310 HEATING GUN

### Heating Gun



- Stepless control on temperature and airflow for optimal settings
- Easy replacement of heating element
- Temperature range: 80 to 530°C
- Airflow range: 0.15 m<sup>3</sup>/min.

### Packing List

FV-310	Unit, Instruction manual
--------	--------------------------



Provided in a carrying case

### Specifications

Power Consumption	1000 W
Maximum Temperature*	530°C (80 to 530°C continuously variable)
Air Velocity	600 m/min.
Air Flow	0.15 to 0.25 m <sup>3</sup> /min.
Dimensions**	240 (W) × 190 (H) × 70 (D) mm
Weight**	0.6 kg

\* Measured at the point 10 mm from the pipe.

\*\* Without cord

## Features

### Stepless control on temperature and airflow for optimal settings

Fine control of temperature and airflow for a variety of application contributes to improvement of work efficiency.



Temperature control knob      Airflow control knob

### Types of applications

A	Drying painting and putty
B	Peeling sticker
C	Shrinking
D	Heat shrink tubing
E	Curving plastic material

### Temperature distribution chart

\* The temperature and airflow volume are reference values; these values are not guaranteed.

Airflow control knob (AIR) \ Temperature control knob (TEMP.)	1	2	3	4	5
<b>1</b> (0.15 m <sup>3</sup> /min.)	120 °C A B C D E	175 °C A B C D E	295 °C A B C D E	425 °C A B C D E	530 °C A B C D E
<b>2</b> (0.17 m <sup>3</sup> /min.)	110 °C A B C D E	165 °C A B C D E	270 °C A B C D E	390 °C A B C D E	505 °C A B C D E
<b>3</b> (0.2 m <sup>3</sup> /min.)	100 °C A B C D E	145 °C A B C D E	230 °C A B C D E	320 °C A B C D E	425 °C A B C D E
<b>4</b> (0.23 m <sup>3</sup> /min.)	90 °C A B C D E	130 °C A B C D E	205 °C A B C D E	285 °C A B C D E	380 °C A B C D E
<b>5</b> (0.25 m <sup>3</sup> /min.)	85 °C A B C D E	115 °C A B C D E	190 °C A B C D E	270 °C A B C D E	345 °C A B C D E

### Easy replacement of heating element

It requires only a screwdriver to remove pipe and replace heating element.

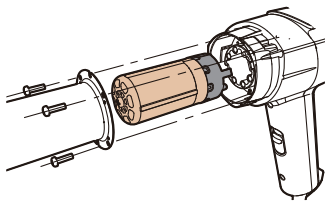

### Safety design for fall-prevention during hands-free operation

Anti-slip rubbers on the back improve stability and safety during hands-free operation.

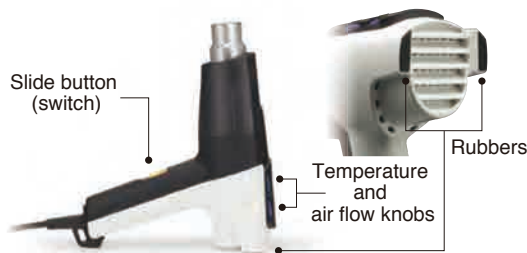

Use of stand, an option part, secures stability for hands-free application.



Stand  
No. B5166

## Option



Drying painting and putty



Heat shrink tubing  
Use of hook type nozzle and stand



Peeling sticker



Shrinking  
Use of spatula type nozzle



Curving plastic material  
Use of nozzle holder and single nozzle



Welding PVC sheet  
Use of nozzle holder and spatula type nozzle along with roller

**Spatula type nozzle 20 mm**  
No. N70-01



**Spatula type nozzle 62 mm**  
No. N70-02



**Hook type nozzle 20 mm**  
No. N70-03



**Hook type nozzle 40 mm**  
No. N70-04



\* Use this nozzle on the nozzle holder (N70-05).

**Nozzle holder**  
No. N70-05



**Single nozzle 12 mm**  
No. N70-06



\* Use this nozzle on the nozzle holder (N70-05).

**Roller**  
No. A1115



## HAKKO MELTER

### Glue Gun



- Glue gun with temperature control function is applicable also to the adhesion of electronic components.
- Useful when fixing up sealing of carton boxes, dressing cases, and packages
- Only used with a stick-type adhesive that is easy to replenish (ø11.5 mm)

### Applications

#### When using polyamide adhesives

- Reinforce and insulate soldered parts
- Fasten capacitors, resistors, etc.
- Fasten jumper wires
- Perform insulation potting for terminals
- Fasten the ends of coils
- Fasten deflecting yokes and variable coils

#### When using EVA adhesives

- Glue paper products (cardboard boxes, gift boxes, etc.)
- Fasten wood products
- Fasten plastics and metals
- Fasten textiles and shock absorbent packing
- Reseal products during packaging

### Packing List

804	Unit, #13 Spanner, #14 Spanner, Instruction manual
-----	--

### Specifications

Model No.	804
Power consumption	100 W
Melting temperature	100 to 200°C (variable)
Standard nozzle	ø2 mm (No. A1083)
Discharge capacity	900 g/h
Dimensions	207 (L) × 173 (H) × 45 (D) mm
Weight*	350 g

\* Without cord

### Adhesive Used

This model has been designed for use with stick adhesives (those hardened into the shape of a stick) only. Be sure to use adhesives recommended by HAKKO.  
(No. 810: UL94V-O recognized)

Part No.	810	811	812
Name	Polyamide	EVA	
Packing	1 kg		14 pcs
Color	Yellowish brown	Milky white	
Size	ø11.5 × 220 mm		
Viscosity	2300 cps. (2300 mPa·s)	5800 cps. (5800 mPa·s)	
Open time*	10 seconds	40 seconds	
Temperature at which adhesive is heat resistant	100°C	55°C	
Suitability	P.W.B.	○	—
	Wood	○	○
	Paper	○	○
	Metal	○	○
	Plastic	○	○
Packing	In aluminum foil bag	In polyethylene bag	In blister pack

Adhesives marked with ○ are more suited for that material than adhesives marked with ○.

\* Application period







#### HEAD OFFICE

4-5, SHIOKUSA 2-CHOME, NANIWA-KU, OSAKA, 556-0024 JAPAN  
TEL: +81-6-6561-3225 FAX: +81-6-6561-8466  
<http://www.hakko.com> E-mail: [sales@hakko.com](mailto:sales@hakko.com)

#### OVERSEAS AFFILIATES

##### U.S.A.

##### AMERICAN HAKKO PRODUCTS, INC.

28920 AVENUE WILLIAMS VALENCIA, CA 91355, U.S.A.  
TEL: (661) 294-0090 FAX: (661) 294-0096  
Toll Free (800)88-HAKKO  
<http://www.hakkousa.com>

##### HONG KONG

##### HAKKO DEVELOPMENT CO., LTD.

ROOM 1504, EASTERN HARBOUR CENTRE,  
28 HOI CHAK STREET, QUARRY BAY, HONG KONG.  
TEL: 2811-5588 FAX: 2590-0217  
<http://www.hakko.com.hk> E-mail: [info@hakko.com.hk](mailto:info@hakko.com.hk)

##### SINGAPORE

##### HAKKO PRODUCTS PTE LTD

1, GENTING LINK #02-04  
PERFECT ONE, SINGAPORE 349518  
TEL: 6748-2277 FAX: 6744-0033  
<http://www.hakko.com.sg> E-mail: [sales@hakko.com.sg](mailto:sales@hakko.com.sg)

Please access to the following address for the other sales affiliates and distributors.

<http://www.hakko.com>



Specifications and design are subject to change without notice.  
Copyright HAKKO Corporation. All rights reserved.

CA00415EbYa005 2018.3



ISO 9001  
ISO 14001

JSAQ181, JSAE601

Production Section only is certified by ISO 9001.



CM001